

Spare parts list

Electric External Vibrators Normal & High frequency

	Valid from serial number
Electric external vibrator ER105 230/400V-3-50Hz	MHN 046463
Electric external vibrator ER105 220/380V-3-60Hz	MHN 046463
Electric external vibrator ER105 500V-3-50Hz	MHN 046463
Electric external vibrator ER105 220/440V-3-60Hz	MHN 046463
Electric external vibrator ER105 230/460V-3-60Hz	MHN 046463
Electric external vibrator ER105 600V-3-60Hz	MHN 046463
Electric external vibrator ER105 240/415V-3-50Hz	MHN 046463
Electric external vibrator ER105 230/400V-3-60Hz	MHN 046463
Electric external vibrator ER205 230/400V-3-50Hz	MHN 046463
Electric external vibrator ER205 220/380V-3-60Hz	MHN 046463
Electric external vibrator ER205 500V-3-50Hz	MHN 046463
Electric external vibrator ER205 220/440V-3-60Hz	MHN 046463
Electric external vibrator ER205 230/460V-3-60Hz	MHN 046463
Electric external vibrator ER205 600V-3-60Hz	MHN 046463
Electric external vibrator ER205 240/415V-3-50Hz	MHN 046463
Electric external vibrator ER205 230/400V-3-60Hz	MHN 046463

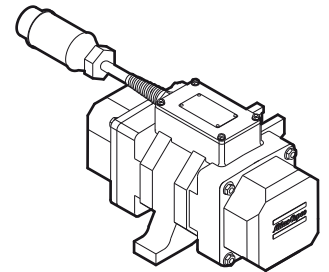
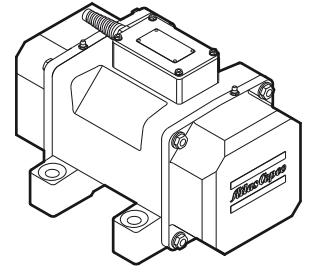

Contents

General information.....	5
Spare parts list.....	8
ER105 50Hz.....	8
ER105 60Hz.....	10
ER205 50Hz.....	12
ER205 60Hz.....	14
ER305 50Hz.....	16
ER305 60Hz.....	18
ER405 50Hz.....	20
ER405 60Hz.....	22
ER505 50Hz.....	24
ER505 60Hz.....	26
ER605 50Hz.....	28
ER605 60Hz.....	30
ER705 50Hz.....	32
ER705 60Hz.....	34
ER207B 200Hz.....	36
ER407B 200Hz.....	38
ER507B 200Hz.....	40

General information

This spare parts list applies to the following:

Part number	Description
4812 0509 10	Electric external vibrator ER105 230/400V-3-50Hz
4812 0509 11	Electric external vibrator ER105 220/380V-3-60Hz
4812 0509 12	Electric external vibrator ER105 500V-3-50Hz
4812 0509 13	Electric external vibrator ER105 220/440V-3-60Hz
4812 0509 14	Electric external vibrator ER105 230/460V-3-60Hz
4812 0509 15	Electric external vibrator ER105 600V-3-60Hz
4812 0509 16	Electric external vibrator ER105 240/415V-3-50Hz
4812 0509 17	Electric external vibrator ER105 230/400V-3-60Hz
4812 0509 20	Electric external vibrator ER205 230/400V-3-50Hz
4812 0509 21	Electric external vibrator ER205 220/380V-3-60Hz
4812 0509 22	Electric external vibrator ER205 500V-3-50Hz
4812 0509 23	Electric external vibrator ER205 220/440V-3-60Hz
4812 0509 24	Electric external vibrator ER205 230/460V-3-60Hz
4812 0509 25	Electric external vibrator ER205 600V-3-60Hz
4812 0509 26	Electric external vibrator ER205 240/415V-3-50Hz
4812 0509 27	Electric external vibrator ER205 230/400V-3-60Hz
4812 0509 30	Electric external vibrator ER305 230/400V-3-50Hz
4812 0509 31	Electric external vibrator ER305 220/380V-3-60Hz
4812 0509 32	Electric external vibrator ER305 500V-3-50Hz
4812 0509 33	Electric external vibrator ER305 220/440V-3-60Hz
4812 0509 34	Electric external vibrator ER305 230/460V-3-60Hz
4812 0509 35	Electric external vibrator ER305 600V-3-60Hz
4812 0509 36	Electric external vibrator ER305 240/415V-3-50Hz
4812 0509 37	Electric external vibrator ER305 230/400V-3-60Hz
4812 0509 40	Electric external vibrator ER405 230/400V-3-50Hz
4812 0509 41	Electric external vibrator ER405 220/380V-3-60Hz
4812 0509 42	Electric external vibrator ER405 500V-3-50Hz
4812 0509 43	Electric external vibrator ER405 220/440V-3-60Hz
4812 0509 44	Electric external vibrator ER405 230/460V-3-60Hz
4812 0509 45	Electric external vibrator ER405 600V-3-60Hz
4812 0509 46	Electric external vibrator ER405 240/415V-3-50Hz
4812 0509 47	Electric external vibrator ER405 230/400V-3-60Hz
4812 0509 50	Electric external vibrator ER505 230/400V-3-50Hz
4812 0509 51	Electric external vibrator ER505 220/380V-3-60Hz
4812 0509 52	Electric external vibrator ER505 500V-3-50Hz
4812 0509 53	Electric external vibrator ER505 220/440V-3-60Hz
4812 0509 54	Electric external vibrator ER505 230/460V-3-60Hz
4812 0509 55	Electric external vibrator ER505 600V-3-60Hz
4812 0509 56	Electric external vibrator ER505 240/415V-3-50Hz
4812 0509 57	Electric external vibrator ER505 230/400V-3-60Hz
4812 0509 60	Electric external vibrator ER605 230/400V-3-50Hz
4812 0509 61	Electric external vibrator ER605 220/380V-3-60Hz
4812 0509 62	Electric external vibrator ER605 500V-3-50Hz
4812 0509 63	Electric external vibrator ER605 220/440V-3-60Hz
4812 0509 64	Electric external vibrator ER605 230/460V-3-60Hz
4812 0509 65	Electric external vibrator ER605 600V-3-60Hz

Part number	Description
4812 0509 66	Electric external vibrator ER605 240/415V-3-50Hz
4812 0509 67	Electric external vibrator ER605 230/400V-3-60Hz
4812 0509 70	Electric external vibrator ER705 230/400V-3-50Hz
4812 0509 71	Electric external vibrator ER705 220/380V-3-60Hz
4812 0509 72	Electric external vibrator ER705 500V-3-50Hz
4812 0509 73	Electric external vibrator ER705 220/440V-3-60Hz
4812 0509 74	Electric external vibrator ER705 230/460V-3-60Hz
4812 0509 75	Electric external vibrator ER705 600V-3-60Hz
4812 0509 76	Electric external vibrator ER705 240/415V-3-50Hz
4812 0509 77	Electric external vibrator ER705 230/400V-3-60Hz
4812 0509 80	Electric external vibrator ER207B 42V-3-200Hz (180Hz)
4812 0509 81	Electric external vibrator ER407B 42V-3-200Hz (180Hz)
4812 0509 82	Electric external vibrator ER507B 42V-3-200Hz (180Hz)
4812 0509 83	Electric external vibrator ER207B 250V-3-200Hz
4812 0509 84	Electric external vibrator ER407B 250V-3-200Hz
4812 0509 85	Electric external vibrator ER507B 250V-3-200Hz

Use only authorized parts. Any damage or malfunction caused by the use of unauthorized parts is not covered by Warranty or Product Liability. Any unauthorized use or copying of the contents or any part thereof is prohibited. This applies in particular to trademarks, model denominations, part numbers, and drawings.

Instructions for use

This spare parts list contains no safety regulations and is merely intended to assist in the ordering of spare parts.

For information about operating, servicing, or repairing, the relevant Safety and operating instructions must be consulted at all costs.

Please observe the safety instructions listed in the relevant Safety and operating instructions!

Spare parts list

ER105 50Hz

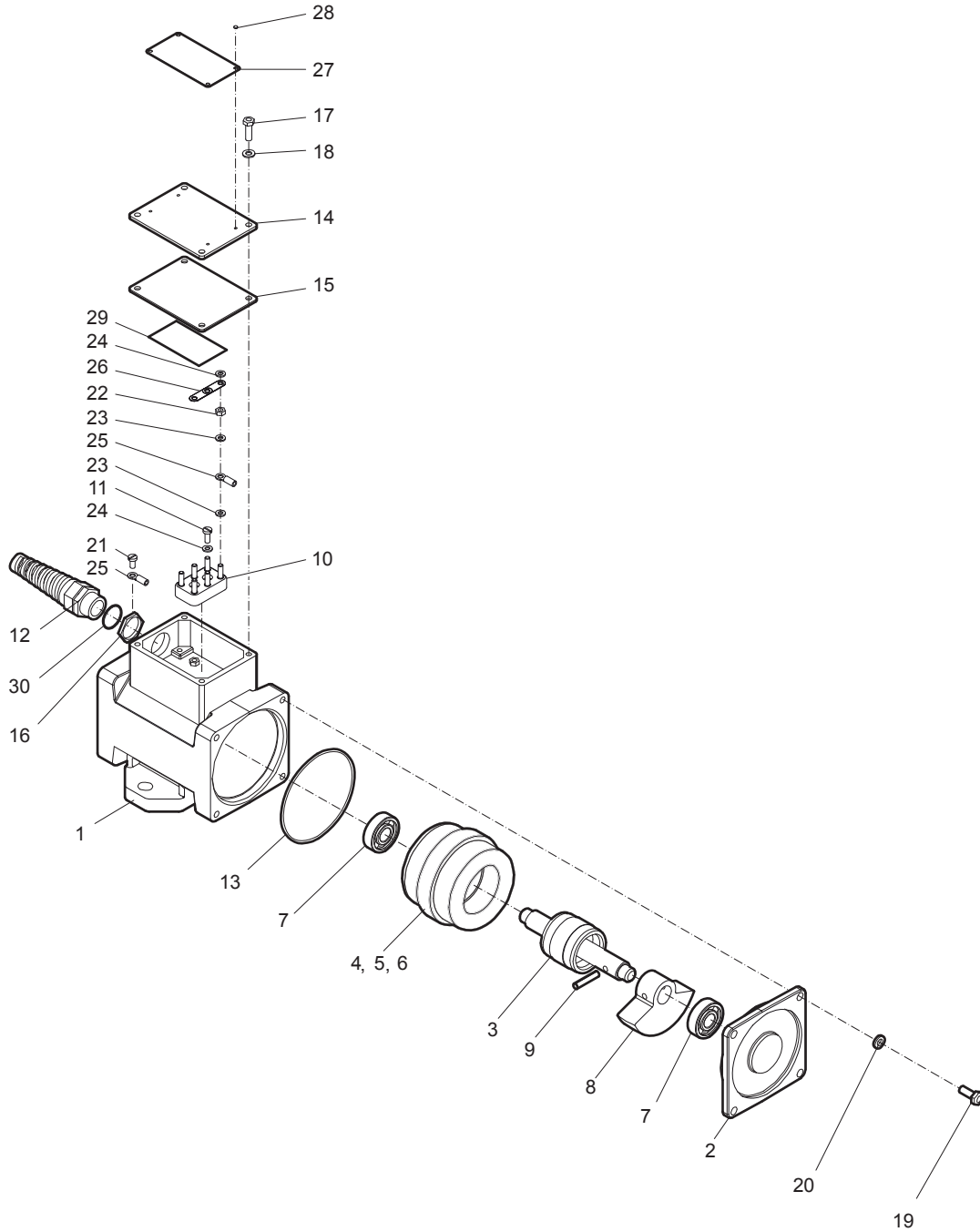

No.	Description	Remark	Quantity	Part number
1	Bolt casing		1	4700 1843 64
2	Bearing bracket		1	4700 1843 66
3	Rotor		1	4700 1847 22
4	Stator	230V/400V-3-50Hz	1	4700 1847 19
5	Stator	500V-3-50Hz	1	4700 1862 22
6	Stator	240/415V-3-50Hz	1	4700 1857 86
7	Bearing		2	4700 1056 86
8	Eccentric		1	4700 1843 69
9	Pin	Ø5 x 24 mm (ISO8752) 0.19 x 0.94 in.	1	4700 6290 38
10	Terminal board	6 poles	1	4700 1036 32
11	Tapping screw	S T 4.2 x 13 mm (DIN7971F)	2	4700 1847 72
12	Gland		1	4700 1848 27
13	O-ring	75.92 x 1.78mm (Shore 70) 2.98 x 0.06 in.	1	4700 1602 28
14	Terminal box cover		1	4700 1843 71
15	Seal		1	4700 1843 72
16	Gland nut		1	4700 1847 73
17	Box cover screw	H M5 x 16 mm CL8.8 (DIN933)	4	-
18	Box cover washer		4	4700 1823 36
19	End cover screw	H M6 x 16 mm CL10.9 (DIN933)	4	4700 5000 13
20	End cover washer		4	4700 1842 27
21	Screw	C S M4 x 8 mm (DIN84A) Brass	1	4700 1859 14
22	Nut	HU M4 (DIN934) Brass	3	4700 1838 97
23	Washer	4.3 x 8 x 0.5 mm (ISO7092) 0.16 x 0.31 x 0.01 in. Brass	12	4700 6150 05
24	Terminal board washer	4.3 x 8 x 0.5 mm (DIN6798 A) 0.16 x 0.31 x 0.01 in.	5	4700 6060 01
25	Spade		6	4700 9600 65
26	Connecting strip		3	4700 1838 96
27	Data plate		1	-
28	Rivet		4	4710 1663 -1
29	Diagram connections		1	4700 2971 43
30	O-ring	14.1 x 1.6 mm (Shore 70) 0.55 x 0.06 in.	1	4700 1603 06

ER105 60Hz

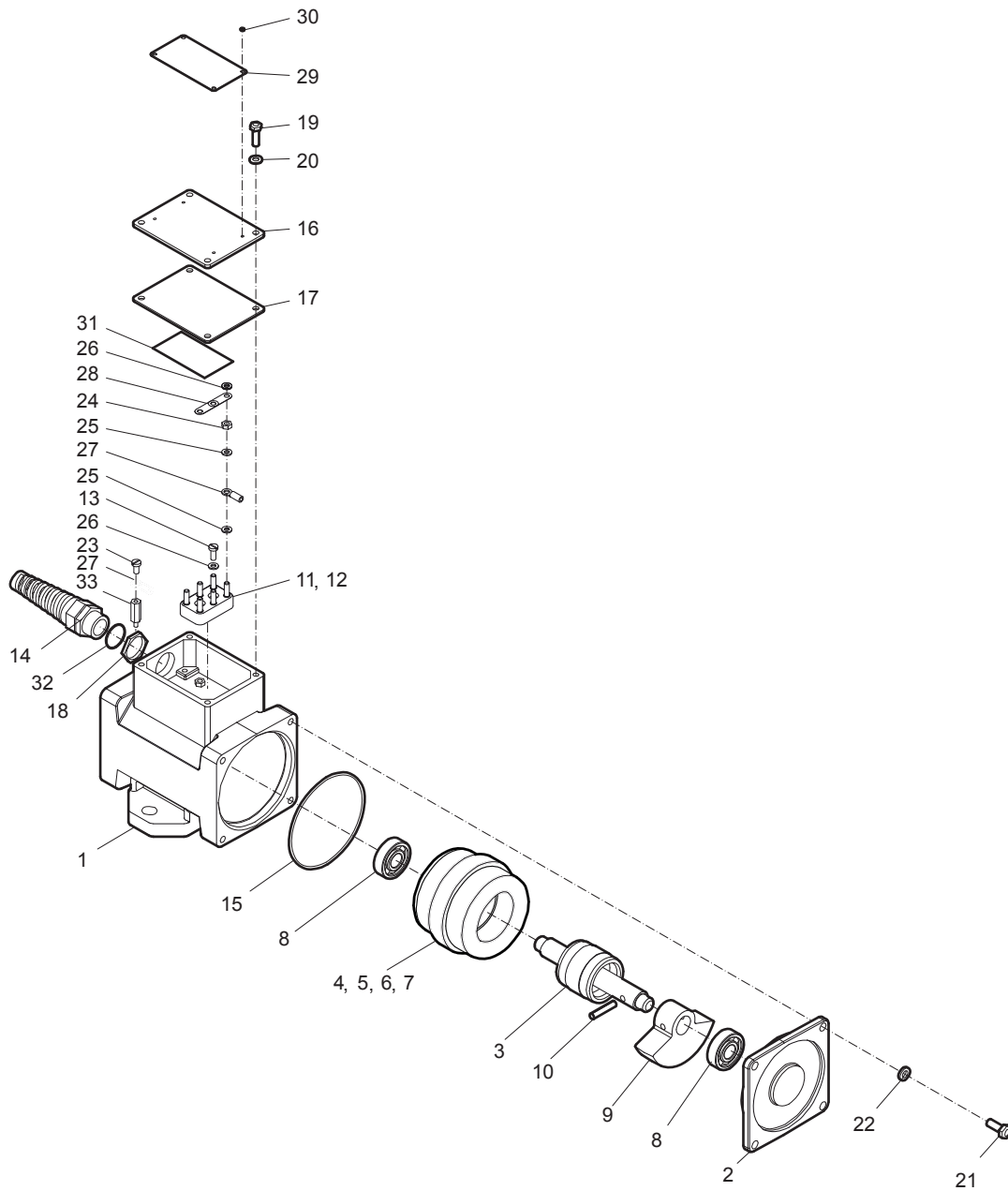

No.	Description	Remark	Quantity	Part number
1	Bolt casing		1	4700 1843 64
2	Bearing bracket		1	4700 1843 66
3	Rotor		1	4700 1847 22
4	Stator	220V/380V-3-60Hz	1	4700 1863 37
5	Stator	220V/440V-3-60Hz	1	4700 3623 04
6	Stator	230V/460V-3-60Hz	1	4700 3648 07
7	Stator	600V-3-60Hz	1	4700 1862 22
8	Bearing		2	4700 1056 86
9	Eccentric		1	4700 1863 34
10	Pin	Ø5 x 24 mm (ISO8752) 0.19 x 0.94 in.	1	4700 6290 38
11	Terminal board	6 poles	1	4700 1036 32
12	Terminal board	9 poles	1	4700 1837 18
13	Tapping screw	S T 4.2 x 13 mm (DIN7971F)	2	4700 1847 72
14	Gland		1	4700 1848 27
15	O-ring	75.92 x 1.78 mm (Shore 70) 2.98 x 0.06 in.	1	4700 1602 28
16	Terminal box cover		1	4700 1843 71
17	Seal		1	4700 1843 72
18	Gland nut		1	4700 1847 73
19	Box cover screw	H M5 x 16 mm CL8.8 (DIN933)	4	-
20	Box cover washer		4	4700 1823 36
21	End cover screw	H M6 x 16 mm CL10.9 (DIN933)	4	4700 5000 13
22	End cover washer		4	4700 1842 27
23	Screw	C S M4 x 8 mm (DIN84A) Brass	1	4700 1859 14
24	Nut	HU M4 (DIN934) Brass	15	4700 1838 97
25	Washer	4.3 x 8 x 0.5 mm (ISO7092) 0.16 x 0.31 x 0.01 in. Brass	6	4700 6150 05
26	Terminal board washer	4.3 x 8 x 0.5 mm (DIN6798 A) 0.16 x 0.31 x 0.01 in.	8	4700 6060 01
27	Spade		9	4700 9600 65
28	Connecting strip		5	4700 1838 96
29	Data plate		1	-
30	Rivet		4	4710 1663 -1
31	Diagram connections		1	4700 2971 43
32	O-ring	14.1 x 1.6 mm (Shore 70) 0.55 x 0.06 in.	1	4700 1603 06
33	Spacer		1	4700 3680 24

ER205 50Hz

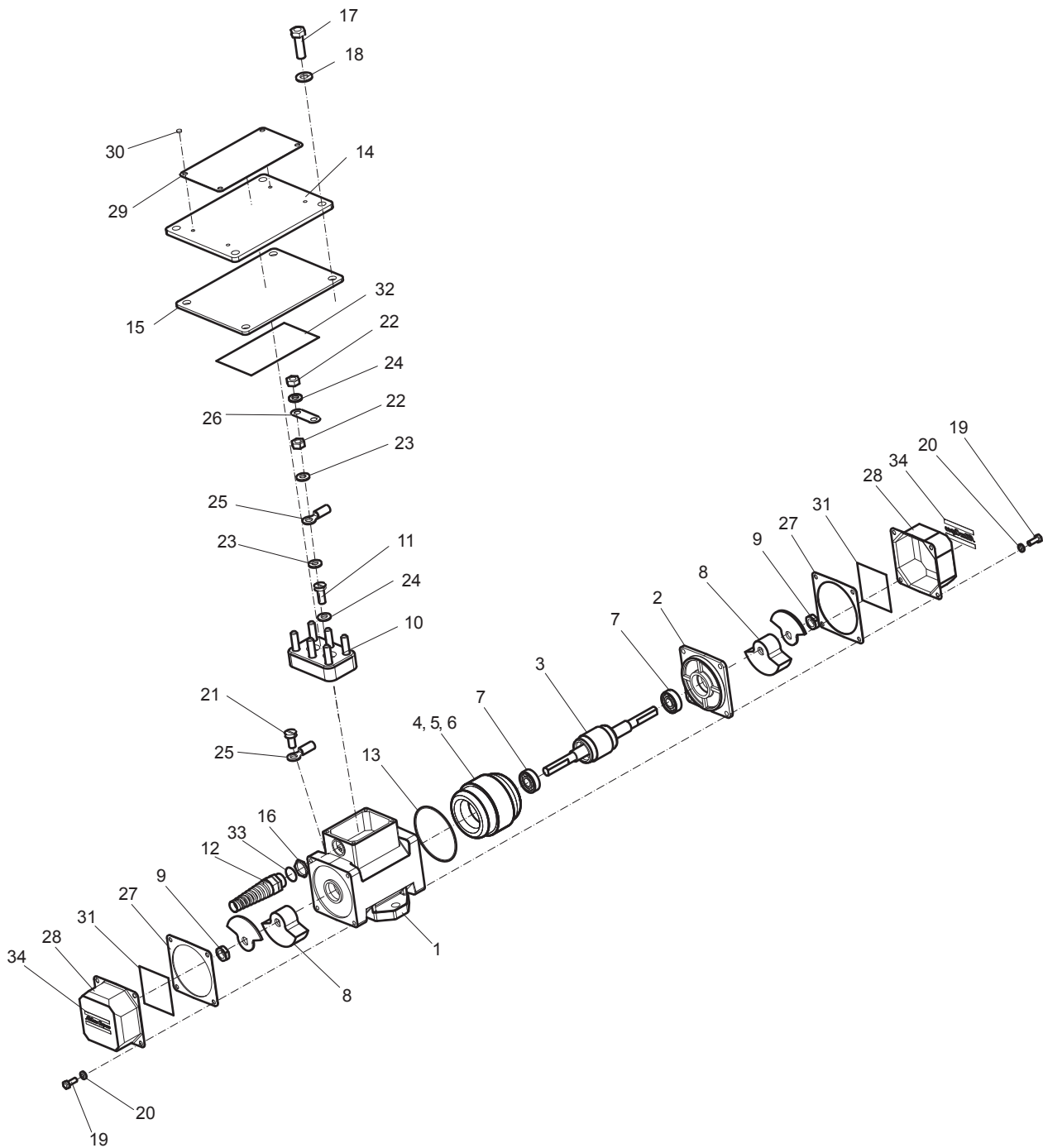

No.	Description	Remark	Quantity	Part number
1	Bolt casing		1	4700 1843 65
2	Bearing bracket		1	4700 1843 67
3	Rotor		1	4700 1847 34
4	Stator	230V/400V-3-50Hz	1	4700 1847 35
5	Stator	500V-3-50Hz	1	4700 1862 25
6	Stator	240V/415V-3-50Hz	1	4700 1863 23
7	Bearing		2	4700 1056 86
8	Eccentric		18	4700 1843 70
9	Nut	HM M12 x 1.25 mm (ISO8673)	2	4700 1847 38
10	Terminal board	6 poles	1	4700 1036 32
11	Terminal board screw	ST 4.2 x 9.5 mm (DIN7981C) POZ	2	4700 5415 08
12	Gland		1	4700 1848 27
13	O-ring	75.92 x 1.78 mm (Shore 70) 75.92 x 0.70 in.	1	4700 1602 28
14	Terminal box cover		1	4700 1843 71
15	Seal		1	4700 1843 72
16	Gland nut		1	4700 1847 73
17	Box cover screw	H M5 x 16 mm CL8.8 (DIN933)	4	-
18	Box cover washer		4	4700 1823 36
19	End cover screw	H M6 x 16 mm CL10.9 (DIN933)	8	4700 5000 13
20	End cover washer		8	4700 1842 27
21	Screw	C S M4 x 8 mm (DIN84A) Brass	1	4700 1859 14
22	Nut	HU M4 (DIN934) Brass	3	4700 1838 97
23	Washer	4.3 x 8 x 0.5 mm (ISO7092) Brass 0.16 x 0.31 x 0.01 in.	6	4700 6150 05
24	Washer	4.3 x 8 x 0.5 mm (DIN6798 A) 0.16 x 0.31 x 0.01 in.	8	4700 6060 01
25	Spade		6	4700 9600 65
26	Connecting strip		3	4700 1838 96
27	Seal		2	4700 1843 73
28	Cover		2	4700 1843 68
29	Data plate		1	-
30	Rivet		4	4710 1663 -1
31	Label		2	4700 1860 66
32	Label		1	4700 2937 37
33	O-ring	14.1 x 1.6 mm (Shore 70) 0.55 x 0.06 in.	1	4700 1603 06
34	Label	"Atlas Copco"	2	4812 0510 61

ER205 60Hz

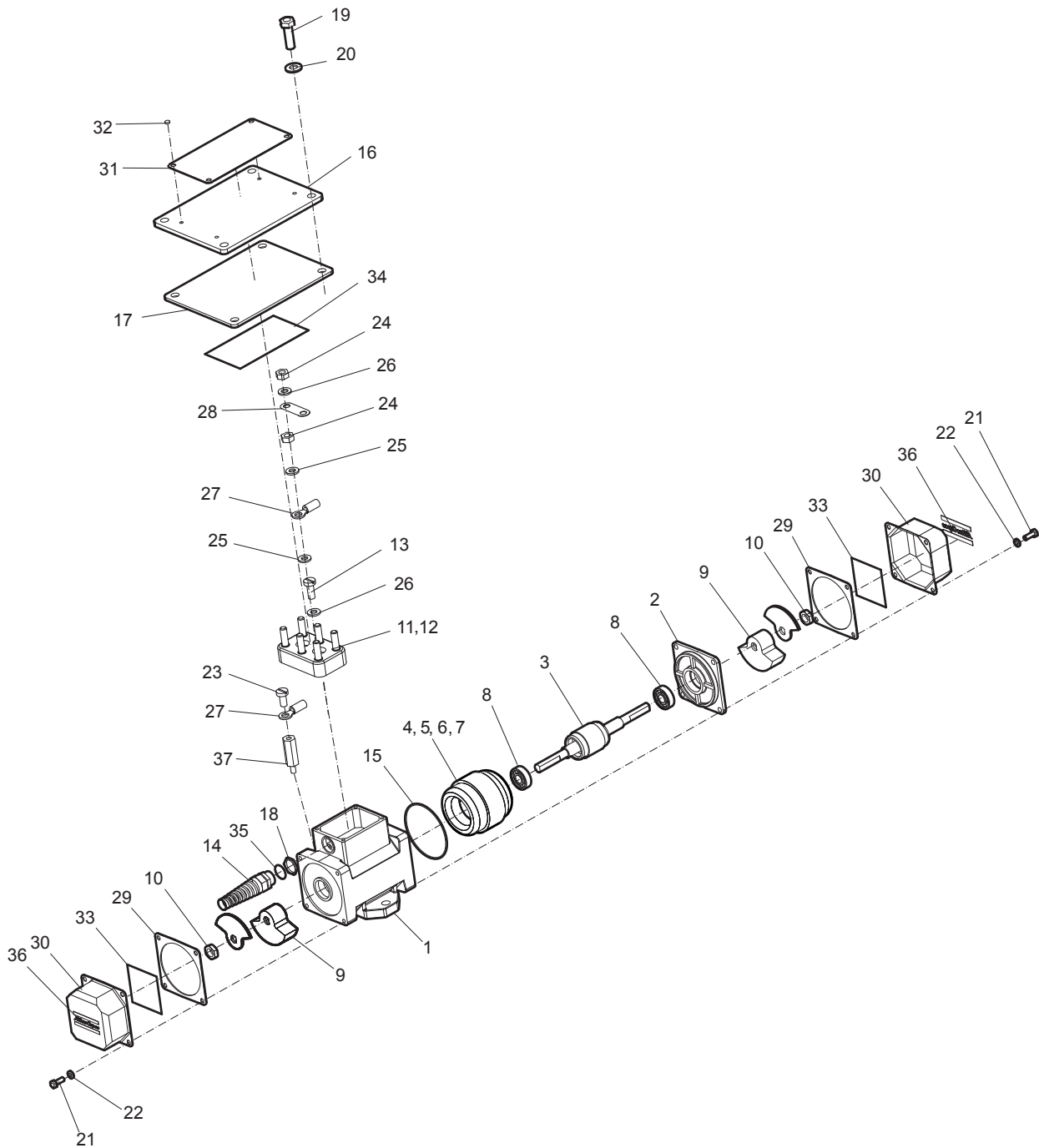

No.	Description	Remark	Quantity	Part number
1	Bolt casing		1	4700 1843 65
2	Bearing bracket		1	4700 1843 67
3	Rotor		1	4700 1847 34
4	Stator	220V/380V-3-60Hz	1	4700 1863 42
5	Stator	220V/440V-3-60Hz	1	4700 1860 62
6	Stator	230V/460V-3-60Hz	1	4700 3657 24
7	Stator	600V-3-60Hz	1	4700 1862 25
8	Bearing		2	4700 1056 86
9	Eccentric		14	4700 1843 70
10	Nut	HM M12 x 1.25 mm (ISO8673)	2	4700 1847 38
11	Terminal board	6 poles*	1	4700 1036 32
12	Terminal board	9 poles*	1	4700 1837 18
13	Terminal board screw	ST 4.2 x 9.5 mm (DIN7981C) POZ	2	4700 5415 08
14	Gland		1	4700 1848 27
15	Bearing bracket o-ring	75.92 x 1.78 mm (Shore 70) 75.92 x 0.70 in.	1	4700 1602 28
16	Terminal box cover		1	4700 1843 71
17	Seal		1	4700 1843 72
18	Gland nut		1	4700 1847 73
19	Box cover screw	H M5 x 16 mm CL8.8 (DIN933)	4	-
20	Box screw washer		4	4700 1823 36
21	End cover screw	H M6 x 16 mm CL10.9 (DIN933)	8	4700 5000 13
22	End cover washer		8	4700 1842 27
23	Screw	C S M4 x 8 mm (DIN84A) Brass	1	4700 1859 14
24	Nut	HU M4 (DIN934) Brass	15	4700 1838 97
25	Washer	4.3 x 8 x 0.5 mm (ISO7092) 0.16 x 0.31 x 0.01 in. Brass	6	4700 6150 05
26	Washer	4.3 x 8 x 0.5 mm (DIN6798 A) 0.16 x 0.31 x 0.01 in.	8	4700 6060 01
27	Spade	6/9 pcs*	9	4700 9600 65
28	Connecting strip		5	4700 1838 96
29	Seal		2	4700 1843 73
30	Cover		2	4700 1843 68
31	Data plate		1	-
32	Rivet		4	4710 1663 -1
33	Label		2	4700 1860 66
34	Label		1	4700 2937 37
35	O-ring	14.1 x 1.6 mm (Shore 70) 0.55 x 0.06 in.	1	4700 1603 06
36	Label	"Atlas Copco"	2	4812 0510 61
37	Spacer		1	4700 3680 24

* depends on the type of vibrator

ER305 50Hz

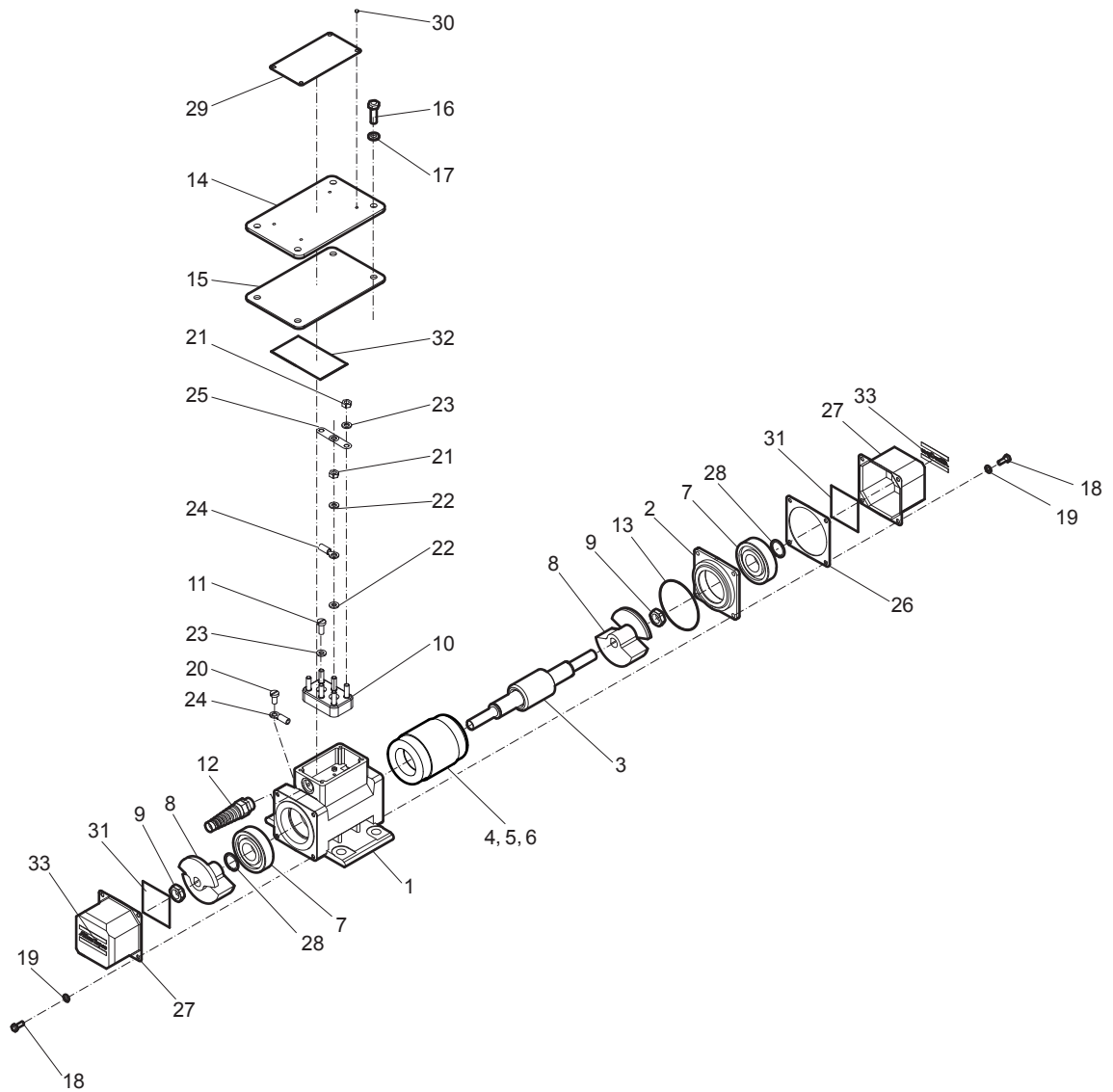

No.	Description	Remark	Quantity	Part number
1	Bolt casing		1	4700 1843 74
2	Bearing bracket		1	4700 1843 76
3	Rotor		1	4700 1847 75
4	Stator	230V/400V-3-50Hz	1	4700 1847 77
5	Stator	500V-3-50Hz	1	4700 1856 33
6	Stator	240V/415V-3-50Hz	1	4700 1860 99
7	Bearing		2	4700 1808 09
8	Eccentric		22	4700 1843 79
9	Nut	HM M16 x 1.50 mm (ISO8673)	2	4700 1847 74
10	Terminal board	6 poles	1	4700 1036 32
11	Screw	C S M4 x 12 mm CL4.8 (DIN84A)	2	4700 5330 09
12	Gland		1	4700 1848 27
13	O-ring	82.3 x 1.78 mm (Shore 70) 3.24 x 0.07 in.	1	4700 1602 29
14	Cover		1	4700 1808 88
15	Rubber sealing		1	4700 1036 93
16	Screw	H M5 x 16 mm CL8.8 (DIN933)	4	-
17	Spring washer		4	4700 1823 36
18	Screw	H M6 x 16 mm CL10.9 (DIN933)	8	4700 5000 13
19	Washer	6.4 x 14 x 1.5 mm (DIN6796) 0.25 x 0.55 x 0.05 in.	8	4700 6150 42
20	Screw	C S M4 x 8 mm CL4.8 (DIN84A)	1	4700 5330 07
21	Nut	HU M4 Brass (DIN934)	3	4700 1838 97
22	Washer	4.3 x 8 x 0.5 mm (ISO7092) 0.16 x 0.31 x 0.01 in. Brass	12	4700 6150 05
23	Washer	4.3 x 8 x 0.5 mm (DIN6798 A) 0.16 x 0.31 x 0.01 in.	5	4700 6060 01
24	Spade		6	4700 9600 65
25	Connecting strip		3	4700 1838 96
26	Paper seal		2	4700 1843 78
27	Screw		2	4700 1843 77
28	Circlip	Ø25 x 1.2 mm (DIN471) 0.98 x 0.04 in.	2	4700 1500 09
29	Data plate		1	-
30	Rivet		4	4710 1663 -1
31	Label		2	4700 1849 70
32	Label		1	4700 2937 37
33	Label	"Atlas Copco"	2	4812 0510 61

ER305 60Hz

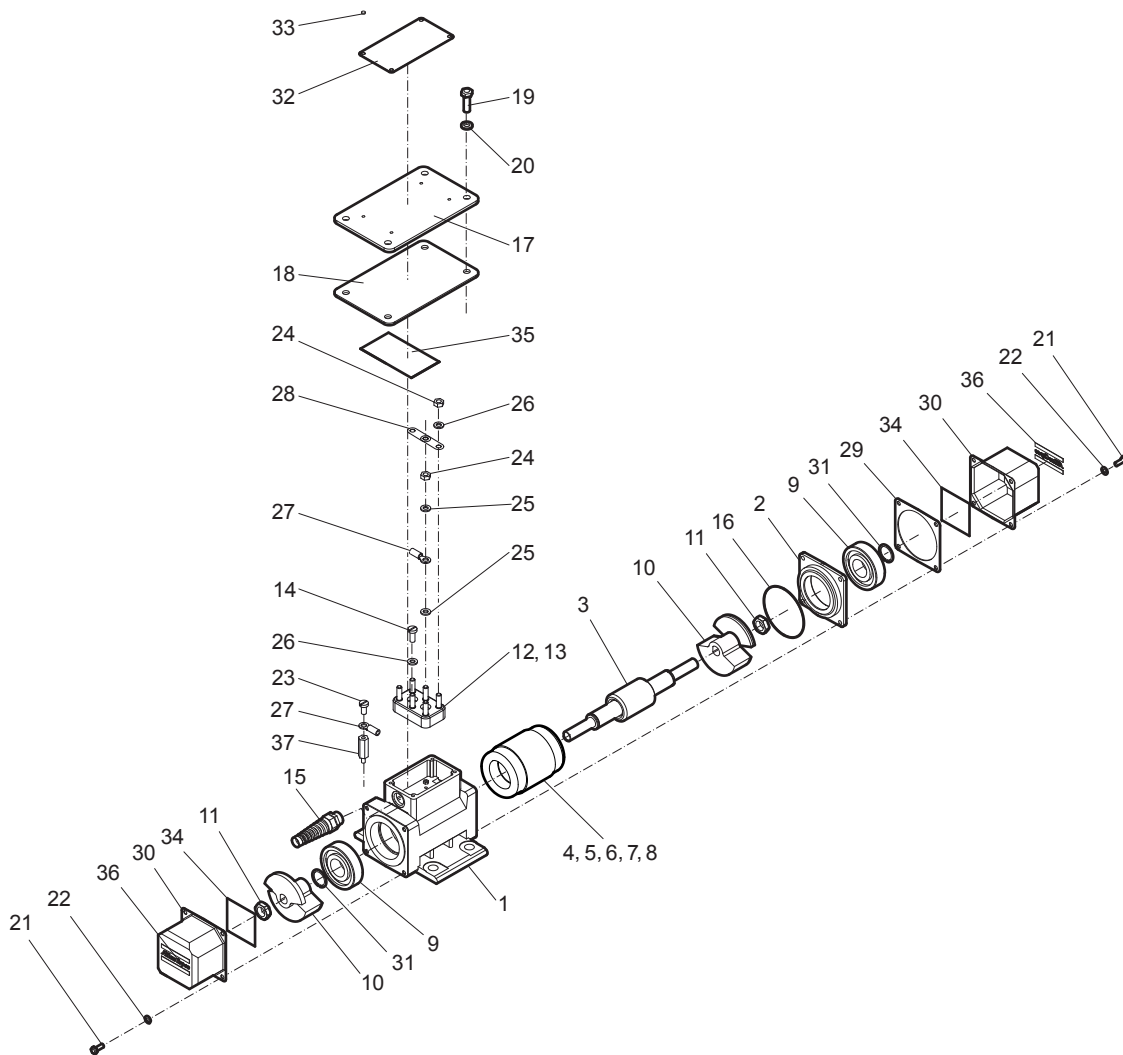

No.	Description	Remark	Quantity	Part number
1	Bolt casing		1	4700 1843 74
2	Bearing bracket		1	4700 1843 76
3	Rotor		1	4700 1847 75
4	Stator	220V/380V-3-60Hz	1	4700 1864 08
5	Stator	220V/440V-3-60Hz	1	4700 1856 29
6	Stator	230V/460V-3-60Hz	1	4700 1863 46
7	Stator	600V-3-60Hz	1	4700 1856 33
8	Stator	230V/400V-3-60Hz	1	4700 1172 15
9	Bearing		2	4700 1808 09
10	Eccentric		22	4700 1856 31
11	Nut	HM M16 x 1.50 mm (ISO8673) 0.62 x 0.05 in.	2	4700 1847 74
12	Terminal board	6 poles*	1	4700 1036 32
13	Terminal board	9 poles*	1	4700 1837 18
14	Screw	C S M4 x 12 mm CL4.8 (DIN84A)	2	4700 5330 09
15	Gland		1	4700 1848 27
16	O-ring	82.3 x 1.78 mm (Shore 70) 3.24 x 0.07 in.	1	4700 1602 29
17	Cover		1	4700 1808 88
18	Rubber sealing		1	4700 1036 93
19	Screw	H M5 x 16 mm CL8.8 (DIN933)	4	-
20	Spring washer		4	4700 1823 36
21	Screw	H M6 x 16 mm CL10.9 (DIN933)	8	4700 5000 13
22	Washer	6.4 x 14 x 1.5 mm (DIN6796) 0.25 x 0.55 x 0.05 in.	8	4700 6150 42
23	Screw	C S M4 x 8 mm CL4.8 (DIN84A)	1	4700 5330 07
24	Nut	HU M4 Brass (DIN934)	15	4700 1838 97
25	Washer	4.3 x 8 x 0.5 mm (ISO7092) 0.16 x 0.31 x 0.01 in. Brass	6	4700 6150 05
26	Washer	4.3 x 8 x 0.5 mm (DIN6798 A) 0.16 x 0.31 x 0.01 in.	5	4700 6060 01
27	Spade	6/9 pcs*	9	4700 9600 65
28	Connecting strip		5	4700 1837 19
29	Paper seal		2	4700 1843 78
30	Screw		2	4700 1843 77
31	Circlip	Ø25 x 1.2 mm (DIN471) 0.98 x 0.04 in.	2	4700 1500 09
32	Data plate		1	-
33	Rivet		4	4710 1663 -1
34	Label		2	4700 1849 70
35	Label		1	4700 2937 37
36	Label	"Atlas Copco"	2	4812 0510 61
37	Spacer		1	4700 3680 24

* depends on the type of vibrator

ER405 50Hz

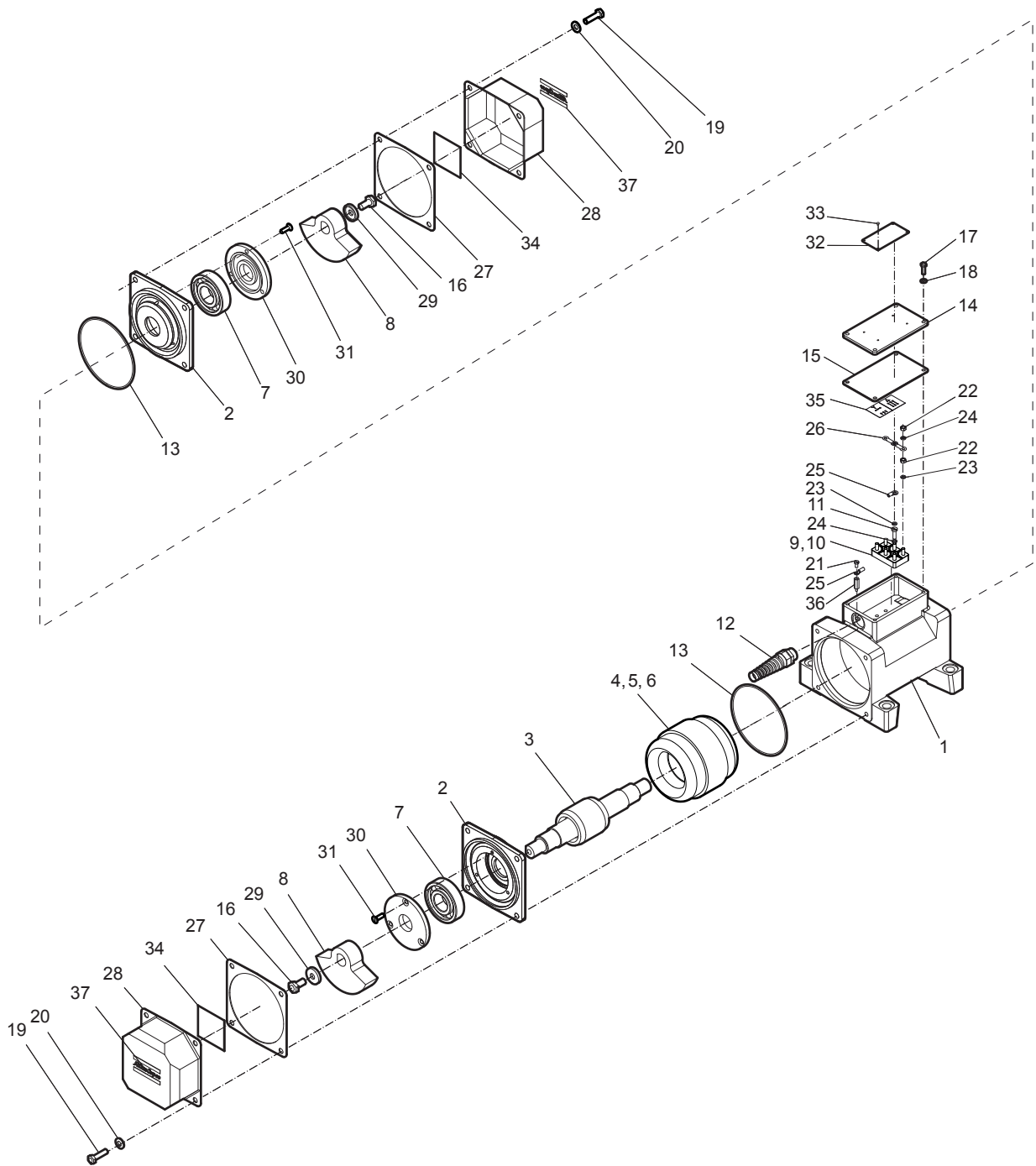

No.	Description	Remark	Quantity	Part number
1	Bolt casing		1	4700 1843 80
2	Bearing bracket		4	4700 1843 81
3	Rotor		1	4700 1847 92
4	Stator	230V/400V-3-50 Hz	1	4700 1847 93
5	Stator	500V-3-50 Hz	1	4700 1859 56
6	Stator	240V/415V-3-50 Hz	1	4700 1858 11
7	Bearing		2	4700 1110 81
8	Eccentric		22	4700 1843 86
9	Terminal board	6 poles*	1	4700 1847 89
10	Terminal board	9 poles*	1	4700 1837 15
11	Terminal board screw	C S M5 x 12 mm CL4.8 (DIN84A)	2	4700 5330 25
12	Gland		1	4700 1848 26
13	O-ring	120.32 x 2.62 mm (Shore 70) 4.73 x 0.10 in.	2	4700 1602 31
14	Cover		1	4700 1843 83
15	Rubber seal		1	4700 1843 84
16	Screw	H M10 x 20 mm CL8.8 (DIN933)	2	-
17	Screw	H M5 x 16 mm CL8.8 (DIN933)	4	-
18	Spring washer		4	4700 1823 36
19	Screw	H M8 x 30 mm CL10.9 (DIN933)	8	4700 5000 22
20	Spring washer		8	4700 6150 43
21	Screw	C S M5 x 8 mm (DIN84A) Brass	1	4700 1859 15
22	Nut	HU M5 (DIN934) Brass	9	4700 1836 94
23	Washer	5.3 x 10 x 1.0 mm (ISO7090) 0.2 x 0.39 x 0.03 Brass	12	4700 6150 01
24	Washer	5.1 x 9 x 0.5 mm (DIN6798 A) 0.2 x 0.35 x 0.01 in.	5	4700 6060 02
25	Spade		6	4700 1800 81
26	Connecting strip		3	4700 1836 93
27	Sealing		2	4700 3681 83
28	Cover		2	4700 1843 82
29	Washer		2	4700 1858 25
30	Bearing cover		2	4700 9322 03
31	Screw	F S M6 x 16 mm CL4.8 (DIN963A)	6	4700 5350 14
32	Data plate		1	-
33	Rivet		4	4710 1663 -1
34	Label		2	4700 1849 71
35	Label		1	4700 2971 43
36	Spacer		1	4700 3680 25
37	Label	"Atlas Copco"	2	4812 0510 93

ER405 60Hz

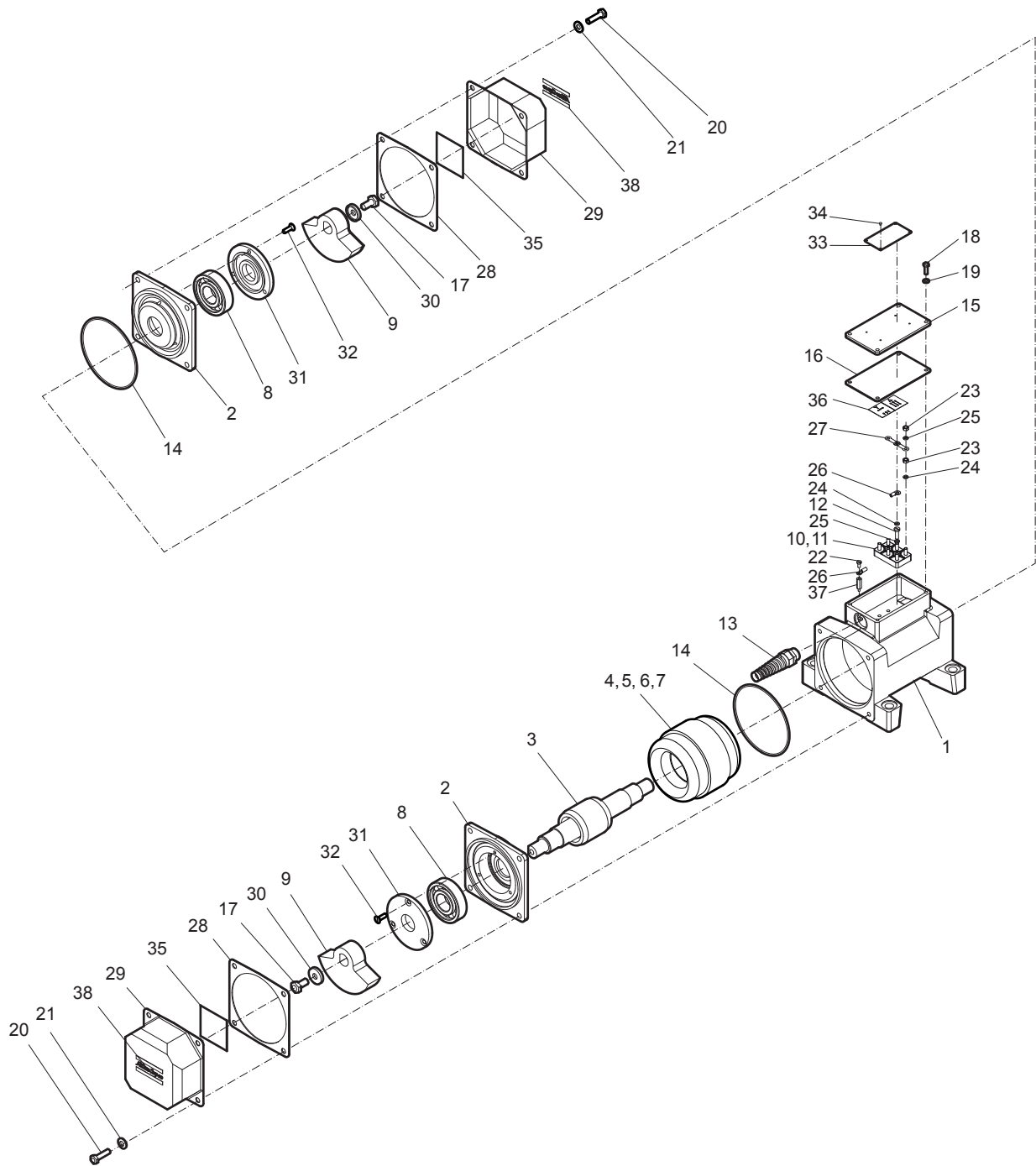

No.	Description	Remark	Quantity	Part number
1	Bolt casing		1	4700 1843 80
2	Bearing bracket		2	4700 1843 81
3	Rotor		1	4700 1847 92
4	Stator	200V/380V-3-60Hz	1	4700 1858 20
5	Stator	220V/440V-3-60Hz	1	4700 1859 69
6	Stator	230V/460V-3-60Hz	1	4700 1862 15
7	Stator	600V-3-60Hz	1	4700 1859 56
8	Bearing		2	4700 1110 81
9	Eccentric		18	4700 1843 86
10	Terminal board	6 poles*	1	4700 1847 89
11	Terminal board	9 poles*	1	4700 1837 15
12	Terminal board screw	C S M5 x 12 mm CL4.8 (DIN84A)	2	4700 5330 25
13	Gland		1	4700 1848 26
14	O-ring	120.32 x 2.62 mm (Shore 70) 4.73 x 0.10 in.	2	4700 1602 31
15	Cover		1	4700 1843 83
16	Rubber seal		1	4700 1843 84
17	Screw	H M10 x 20 mm CL8.8 (DIN933)	2	-
18	Screw	H M5 x 16 mm CL8.8 (DIN933)	4	-
19	Spring washer		4	4700 1823 36
20	Screw	H M8 x 30 mm CL10.9 (DIN933)	8	4700 5000 22
21	Spring washer		8	4700 6150 43
22	Screw	C S M5 x 8 mm (DIN84A) Brass	1	4700 1859 15
23	Nut	HU M5 (DIN934) Brass	15	4700 1836 94
24	Washer	5.3 x 10 x 1.0 mm (ISO7090) 0.2 x 0.39 x 0.03 Brass	9	4700 6150 01
25	Washer	5.1 x 9 x 0.5 mm (DIN6798 A) 0.2 x 0.35 x 0.01 in.	11	4700 6060 02
26	Nut		9	4700 1800 81
27	Connecting strip		5	4700 1836 93
28	Sealing		2	4700 3681 83
29	Cover		2	4700 1843 82
30	Washer		2	4700 1858 25
31	Bearing cover		2	4700 9322 03
32	Screw	F S M6 x 16 mm CL4.8 (DIN963A)	6	4700 5350 14
33	Data plate		1	-
34	Rivet		4	4710 1663 -1
35	Label		2	4700 1849 71
36	Label		1	4700 2971 43
37	Spacer		1	4700 3680 25
38	Label	"Atlas Copco"	2	4812 0510 93

* depends on the type of vibrator

ER505 50Hz

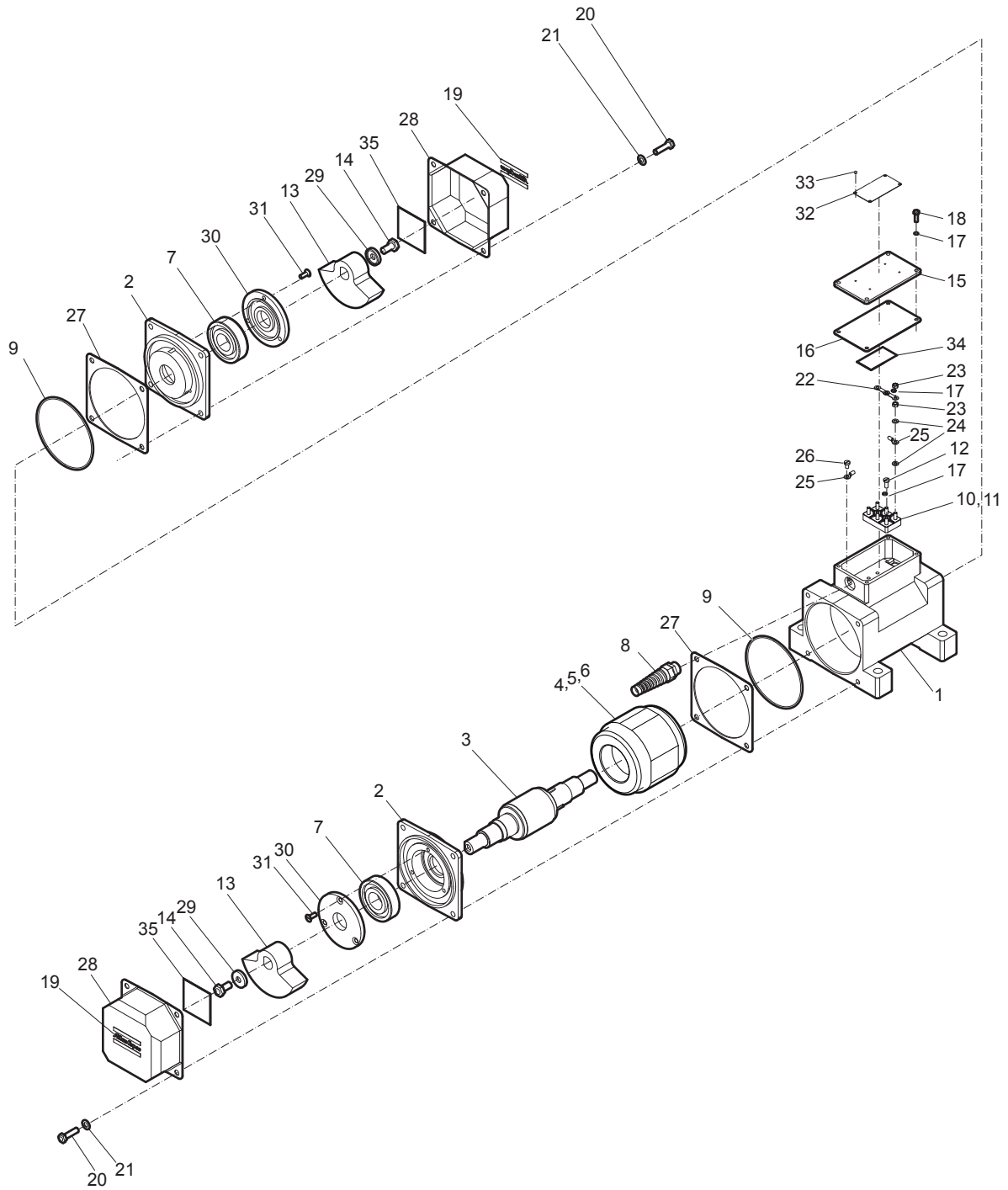

No.	Description	Remark	Quantity	Part number
1	Bolt casing		1	4700 1843 80
2	Bearing bracket		2	4700 1843 81
3	Rotor		1	4700 1847 85
4	Stator	230V/400V-3-50Hz	1	4700 9322 05
5	Stator	500V-3-50Hz	1	4700 9322 48
6	Stator	240V/415V-3-50Hz	1	4700 9322 88
7	Bearing		2	4700 1110 81
8	Gland		1	4700 1848 26
9	O-ring	120.32 x 2.62 mm (Shore 70) 4.73 x 0.10 in.	2	4700 1602 31
10	Terminal board	6 poles*	1	4700 1847 89
11	Terminal board	9 poles*	1	4700 1837 15
12	Terminal board screw		2	4700 5330 25
13	Eccentric		22	4700 1843 87
14	Screw	H M10 x 20 mm CL8.8 (DIN933)	2	-
15	Cover		1	4700 1843 83
16	Rubber seal		1	4700 1843 84
17	Terminal board washer		9	4700 6060 02
18	Screw	H M5 x 16 mm CL8.8 (DIN933)	4	-
19	Label	"Atlas Copco"	2	4812 0510 65
20	Screw	H M8 x 30 mm CL10.9 (DIN933)	8	4700 5000 22
21	Spring washer		8	4700 6150 43
22	Connecting strip		3	4700 1836 93
23	Nut	HU M5 (DIN934) Brass	9	4700 1836 94
24	Washer		12	4700 6150 01
25	Spade		6	4700 1800 81
26	Screw	C S M5 x 8 mm (DIN84A) Brass	1	4700 1859 15
27	Sealing		2	4700 1843 85
28	Cover		2	4700 1843 82
29	Washer		2	4700 1858 25
30	Bearing cover		2	4700 9322 03
31	Screw	F S M6 x 16 mm CL4.8 (DIN963A)	6	4700 5350 14
32	Data plate		1	-
33	Rivet		4	4710 1663 -1
34	Label		1	4700 2971 43
35	Label		2	4700 1849 70

* depends on the type of vibrator

ER505 60Hz

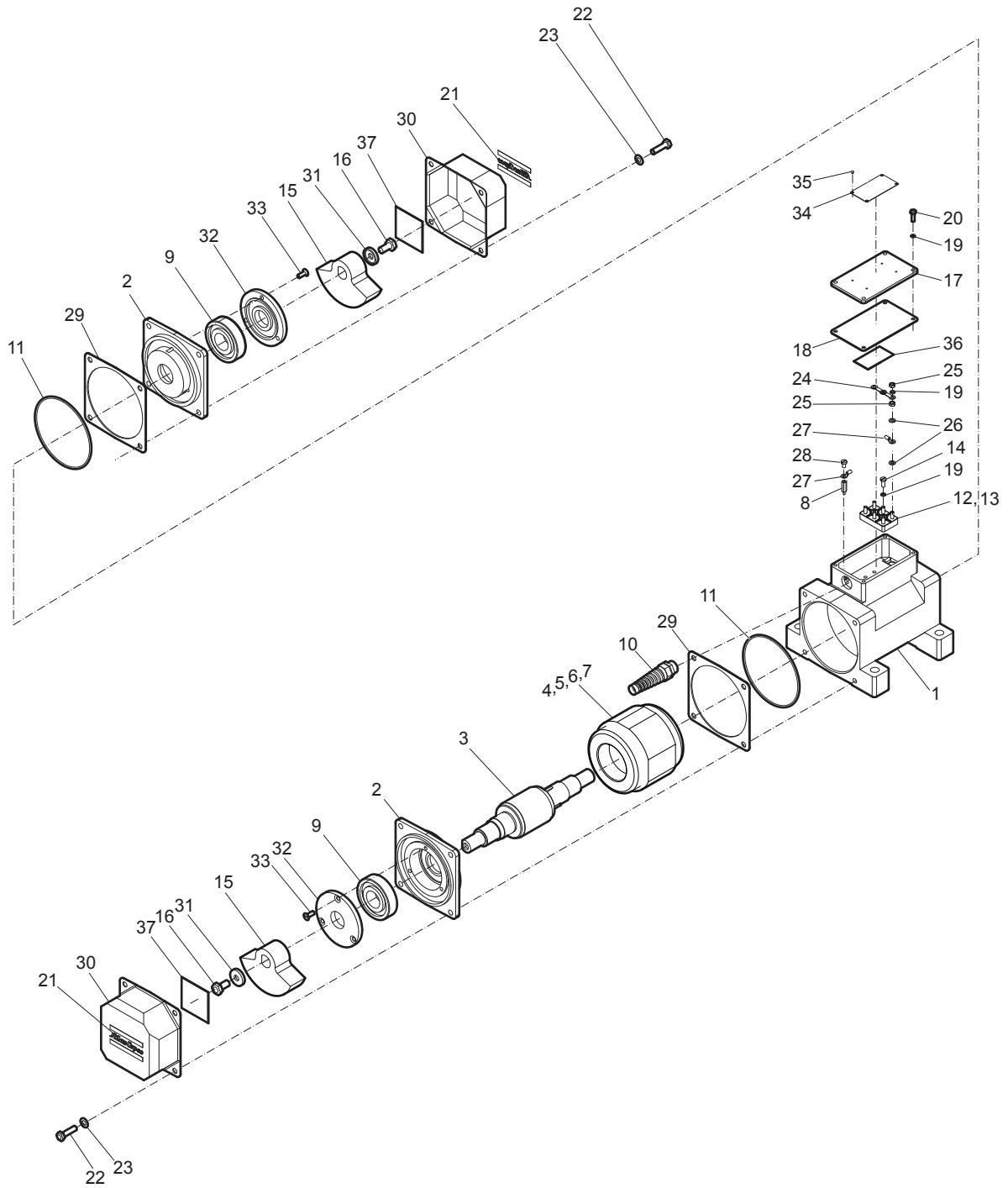

No.	Description	Remark	Quantity	Part number
1	Bolt casing		1	4700 1843 80
2	Bearing bracket		2	4700 1843 81
3	Rotor		1	4700 1847 85
4	Stator	200V/380V-3-60Hz	1	4700 9322 00
5	Stator	220V/440V-3-60Hz	1	4700 9322 25
6	Stator	230V/460V-3-60Hz	1	4700 1852 97
7	Stator	230V/400V-3-60Hz	1	4700 3619 48
8	Spacer		1	4700 3680 25
9	Bearing		2	4700 1110 81
10	Gland		1	4700 1848 26
11	O-ring	120.32 x 2.62 mm (Shore 70) 4.73 x 0.10 in.	2	4700 1602 31
12	Terminal board	6 poles*	1	4700 1847 89
13	Terminal board	9 poles*	1	4700 1837 15
14	Terminal board screw		2	4700 5330 25
15	Eccentric		22	4700 1843 86
16	Screw	H M10 x 20 mm CL8.8 (DIN933)	2	-
17	Cover		1	4700 1843 83
18	Rubber seal		1	4700 1843 84
19	Washer		15	4700 6060 02
20	Screw	H M5 x 16 mm CL8.8 (DIN933)	4	-
21	Label	"Atlas Copco"	2	4812 0510 65
22	Screw	H M8 x 30 mm CL10.9 (DIN933)	8	4700 5000 22
23	Spring washer		8	4700 6150 43
24	Connecting strip		5	4700 1836 93
25	Nut	HU M5 (DIN934) Brass	15	4700 1836 94
26	Washer		9	4700 6150 01
27	Spade	6/9 pcs*	9	4700 1800 81
28	Screw	C S M5 x 8 mm (DIN84A) Brass	1	4700 1859 15
29	Sealing		2	4700 1843 85
30	Cover		2	4700 1843 82
31	Washer		2	4700 1858 25
32	Bearing cover		2	4700 9322 03
33	Screw	F S M6 x 16 mm CL4.8 (DIN963A)	6	4700 5350 14
34	Data plate		1	-
35	Rivet		4	4710 1663 -1
36	Label		1	4700 2971 43
37	Label		2	4700 1849 70

* depends on the type of vibrator

ER605 50Hz

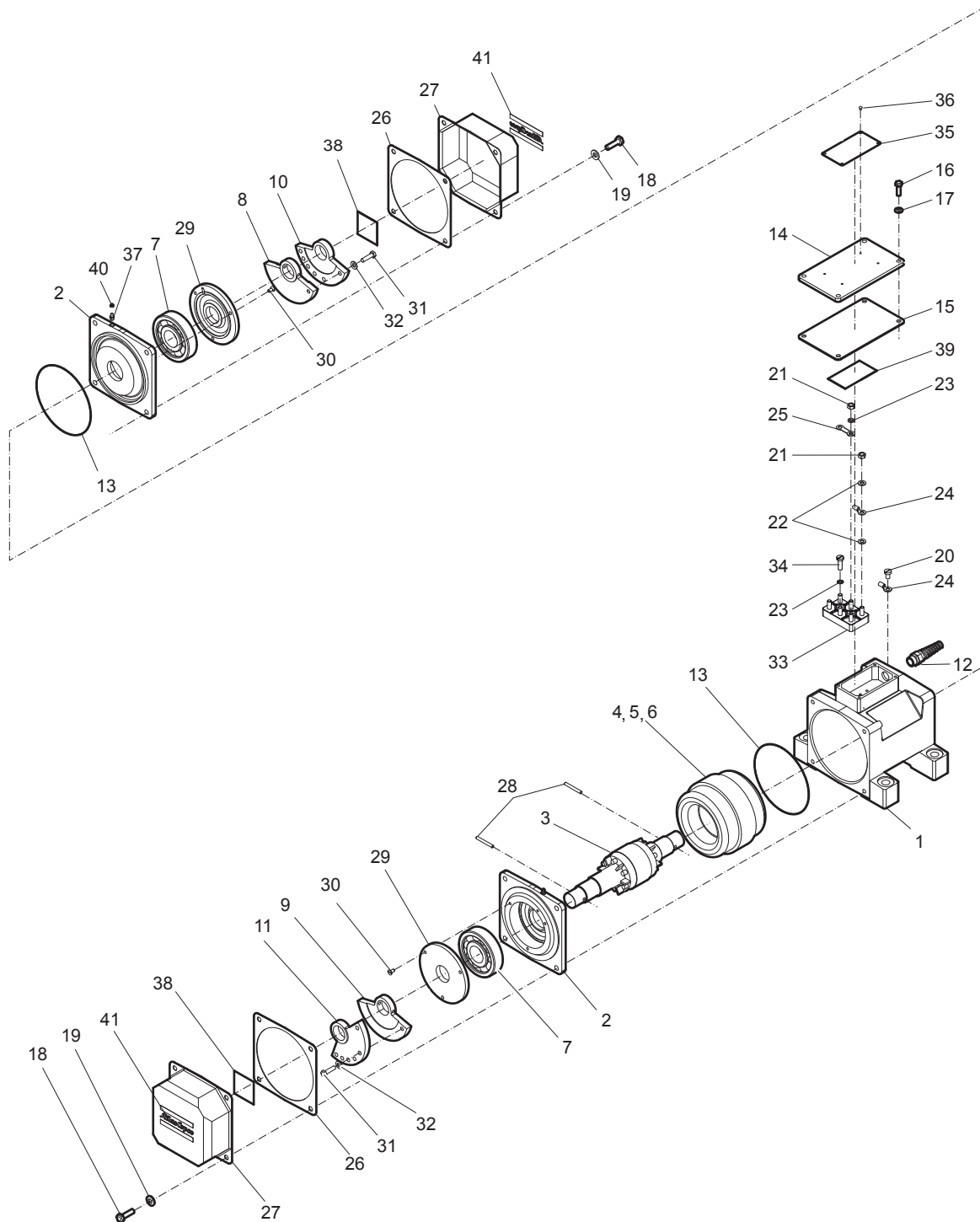

No.	Description	Remark	Quantity	Part number
1	Bolt casing		1	4700 1847 52
2	Bearing bracket		2	4700 1847 53
3	Rotor		1	4700 1848 71
4	Stator	230V/400V-3-50Hz	1	4700 1848 72
5	Stator	500V-3-50Hz	1	4700 1862 30
6	Stator	240V/415V-3-50Hz	1	4700 3666 49
7	Bearing		2	4700 1112 38
8	Fixed eccentric		1	4700 1847 55
9	Fixed eccentric		1	4700 1848 66
10	Adjustable eccentric		1	4700 1848 65
11	Adjustable eccentric		1	4700 1847 54
12	Gland		1	4700 1848 26
13	O-ring	158.42 x 2.62 mm (Shore 70) 6.23 x 0.10 in.	2	4700 1853 08
14	Terminal box cover		1	4700 1843 83
15	Seal		1	4700 1843 84
16	Box cover screw	H M5 x 16 mm CL8.8 (DIN933)	4	-
17	Box cover washer		4	4700 1823 36
18	End cover screw	H M6 x 16 mm CL10.9 (DIN933)	8	4700 5000 30
19	End cover washer		8	4700 6150 44
20	Screw		1	4700 1859 15
21	Nut		9	4700 1836 94
22	Washer		9	4700 6150 01
23	Terminal board washer		5	4700 6060 02
24	Spade		6	4700 1800 81
25	Connecting strip		3	4700 1836 93
26	End cover seal		2	4700 1848 73
27	End cover		2	4700 1847 58
28	Pin	Ø6 x 50 mm (ISO8752) 0.23 x 1.96 in.	2	4700 6290 43
29	Bearing cover		2	4700 9324 07
30	Bearing cover screw	F S M6 x 16 mm CL4.8 (DIN963A)	6	4700 5350 14
31	Eccentric screw	H M8 x 30 mm CL10.9 (DIN933)	2	4700 5000 22
32	Eccentric washer	M8 (DIN6796)	2	4700 6150 43
33	Terminal board	6 poles	1	4700 1847 89
34	Terminal board screw	C S M5 x 16 mm CL4.8 (DIN84A)	2	4700 5330 27
35	Data plate		1	-
36	Rivet		4	4710 1663 -1
37	Grease nipple		2	4700 0019 05
38	Centrifugal force label		2	4700 1853 09
39	Diagramm conection		1	4700 2971 43
40	Grease nipple cap		2	4700 4992 01
41	Label	"Atlas Copco"	2	4812 0510 65

ER605 60Hz

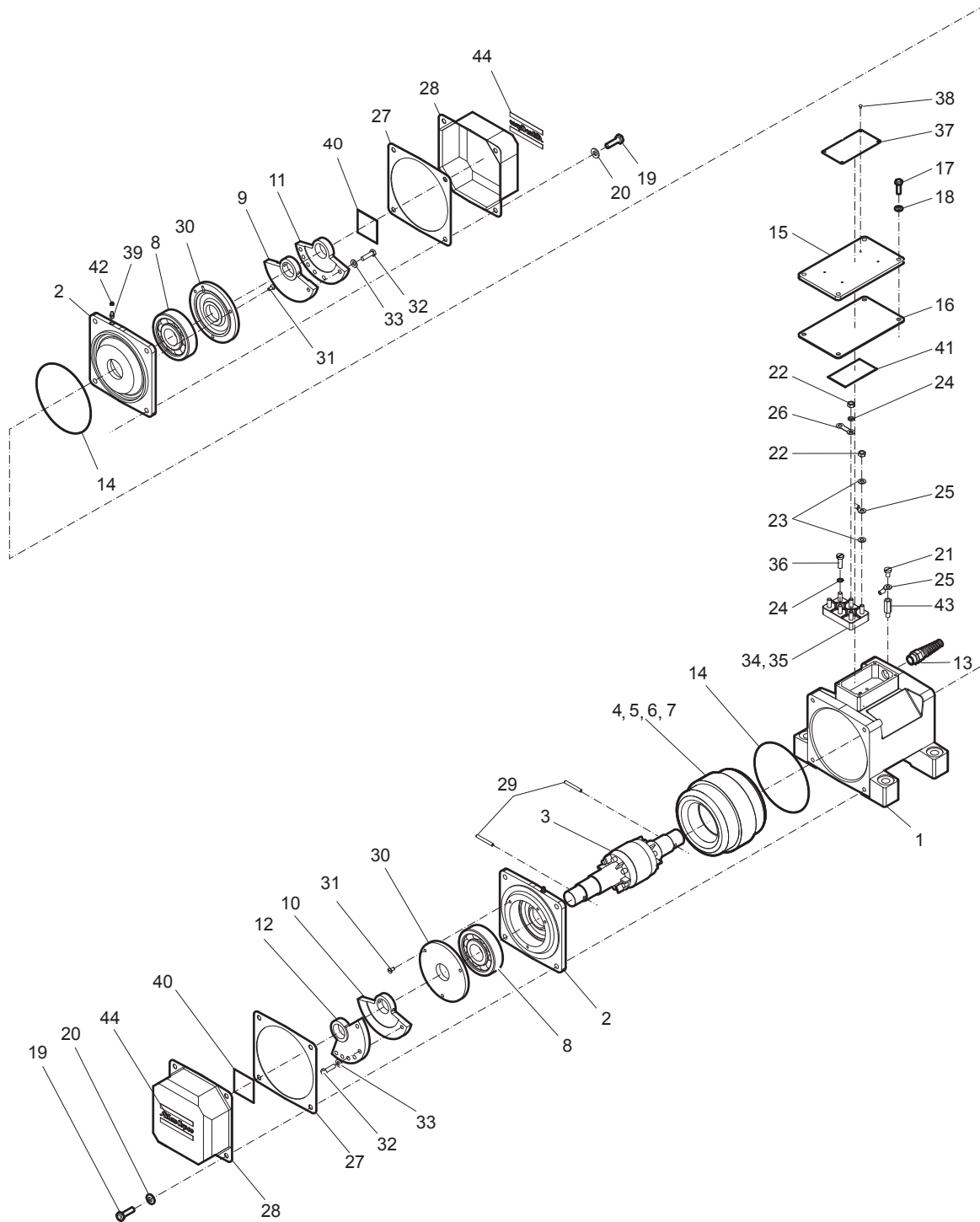

No.	Description	Remark	Quantity	Part number
1	Bolt casing		1	4700 1847 52
2	Bearing bracket		2	4700 1847 53
3	Rotor		1	4700 1848 71
4	Stator	220V/380V-3-60Hz	1	4700 3660 66
5	Stator	220V/440V-3-60Hz	1	4700 1863 63
6	Stator	230V/460V-3-60Hz	1	4700 3657 28
7	Stator	600V-3-60Hz	1	4700 1862 30
8	Bearing		2	4700 1112 38
9	Adjustable eccentric		1	4700 1860 91
10	Adjustable eccentric		1	4700 1860 89
11	Fixed eccentric		1	4700 1860 92
12	Fixed eccentric		1	4700 1860 90
13	Gland		1	4700 1848 26
14	O-ring	158.42 x 2.62 mm (Shore 70) 6.23 x 0.10 in.	2	4700 1853 08
15	Terminal box cover		1	4700 1843 83
16	Seal		1	4700 1843 84
17	Box cover screw	H M5 x 16 mm CL8.8 (DIN933)	4	-
18	Box cover washer		4	4700 1823 36
19	End cover screw	H M6 x 16 mm CL10.9 (DIN933)	8	4700 5000 30
20	End cover washer		8	4700 6150 44
21	Screw		1	4700 1859 15
22	Nut		15	4700 1836 94
23	Washer		6	4700 6150 01
24	Terminal board washer		5	4700 6060 02
25	Spade		9	4700 1500 09
26	Connecting strip		3	4700 1836 93
27	End cover seal		2	4700 1848 73
28	End cover		2	4700 1847 58
29	Pin	Ø6 x 50 mm (ISO8752) 0.23 x 1.96 in.	2	4700 6290 43
30	Bearing cover		2	4700 9324 07
31	Bearing cover screw	F S M6 x 16 mm CL4.8 (DIN963A)	6	4700 5350 14
32	Eccentric screw	H M8 x 30 mm CL10.9 (DIN933)	2	4700 5000 22
33	Eccentric washer	M8 (DIN6796)	2	4700 6150 43
34	Terminal board	6 poles*	1	4700 1847 89
35	Terminal board	9 poles*	1	4700 1837 15
36	Terminal board screw	C S M5 x 16 mm CL4.8 (DIN84A)	2	4700 5330 27
37	Data plate		1	-
38	Rivet		4	4710 1663 -1
39	Grease nipple		2	4700 0019 05
40	Centrifugal force label		2	4700 1853 09
41	Diagramm connection		1	4700 2971 43
42	Grease nipple cap		2	4700 4992 01
43	Spacer		1	4700 3680 25
44	Label	"Atlas Copco"	2	4812 0510 65

* depends on the type of vibrator

ER705 50Hz

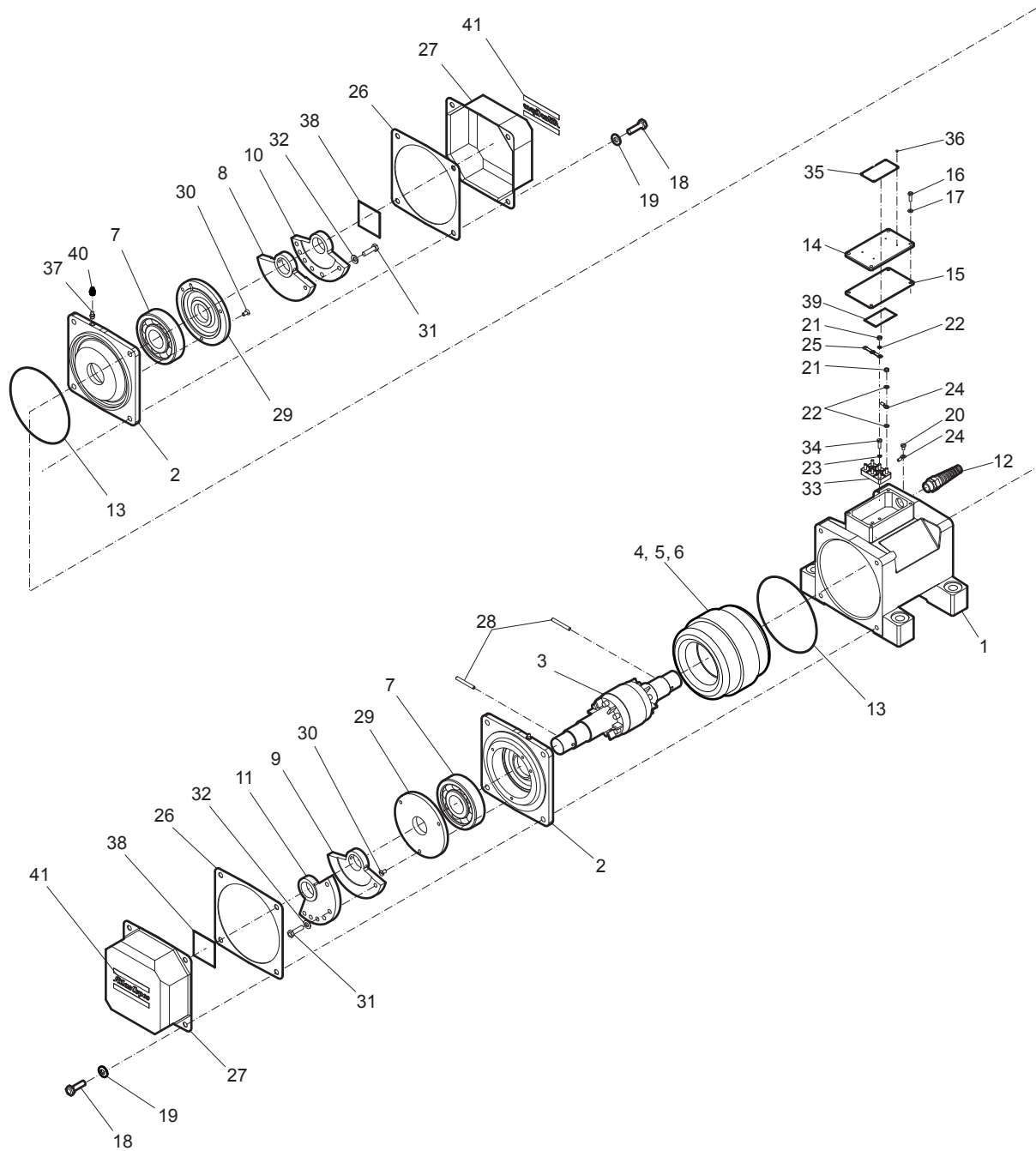

No.	Description	Remark	Quantity	Part number
1	Bolt casing		1	4700 1847 52
2	Bearing bracket		2	4700 1847 53
3	Rotor		1	4700 1848 69
4	Stator	230V/400V-3-50Hz	1	4700 1848 70
5	Stator	500V-3-50Hz	1	4700 1862 34
6	Stator	240V/415V-3-50Hz	1	4700 1866 17
7	Bearing		2	4700 1112 38
8	Fixed eccentric		1	4700 1847 57
9	Fixed eccentric		1	4700 1848 68
10	Adjustable eccentric		1	4700 1848 67
11	Adjustable eccentric		1	4700 1847 56
12	Gland		1	4700 1848 26
13	O-ring	158.42 x 2.62 mm (Shore 70) 6.23 x 0.10 in.	2	4700 1853 08
14	Terminal box cover		1	4700 1843 83
15	Seal		1	4700 1843 84
16	Box cover screw	H M5 x 16 mm CL8.8 (DIN933)	4	-
17	Box cover washer		4	4700 1823 36
18	End cover screw	H M6 x 16 mm CL10.9 (DIN933)	8	4700 5000 30
19	End cover washer		8	4700 6150 44
20	Screw		1	4700 1859 15
21	Nut		9	4700 1836 94
22	Washer		12	4700 6150 01
23	Terminal board washer		5	4700 6060 02
24	Spade		6	4700 1800 81
25	Terminal		3	4700 1836 93
26	End cover seal		2	4700 1848 73
27	End cover		2	4700 1847 58
28	Pin	Ø6 x 50 mm (ISO8752) 0.23 x 1.96 in.	2	4700 6290 43
29	Bearing cover		2	4700 9324 07
30	Bearing cover screw	F S M6 x 16 mm CL4.8 (DIN963A)	6	4700 5350 14
31	Eccentric screw	H M8 x 30 mm CL10.9 (DIN933)	2	4700 5000 22
32	Eccentric washer	M8 (DIN6796)	2	4700 6150 43
33	Terminal board	6 poles	1	4700 1847 89
34	Terminal board screw	C S M5 x 16 mm CL4.8 (DIN84A)	2	4700 5330 27
35	Data plate		1	-
36	Rivet		4	4710 1663 -1
37	Grease nipple		2	4700 0019 05
38	Centrifugal force label		2	4700 1853 09
39	Diagramm connection		1	4700 2971 43
40	Grease nipple cap		2	4700 4992 01
41	Label	"Atlas Copco"	2	4812 0510 65

ER705 60Hz

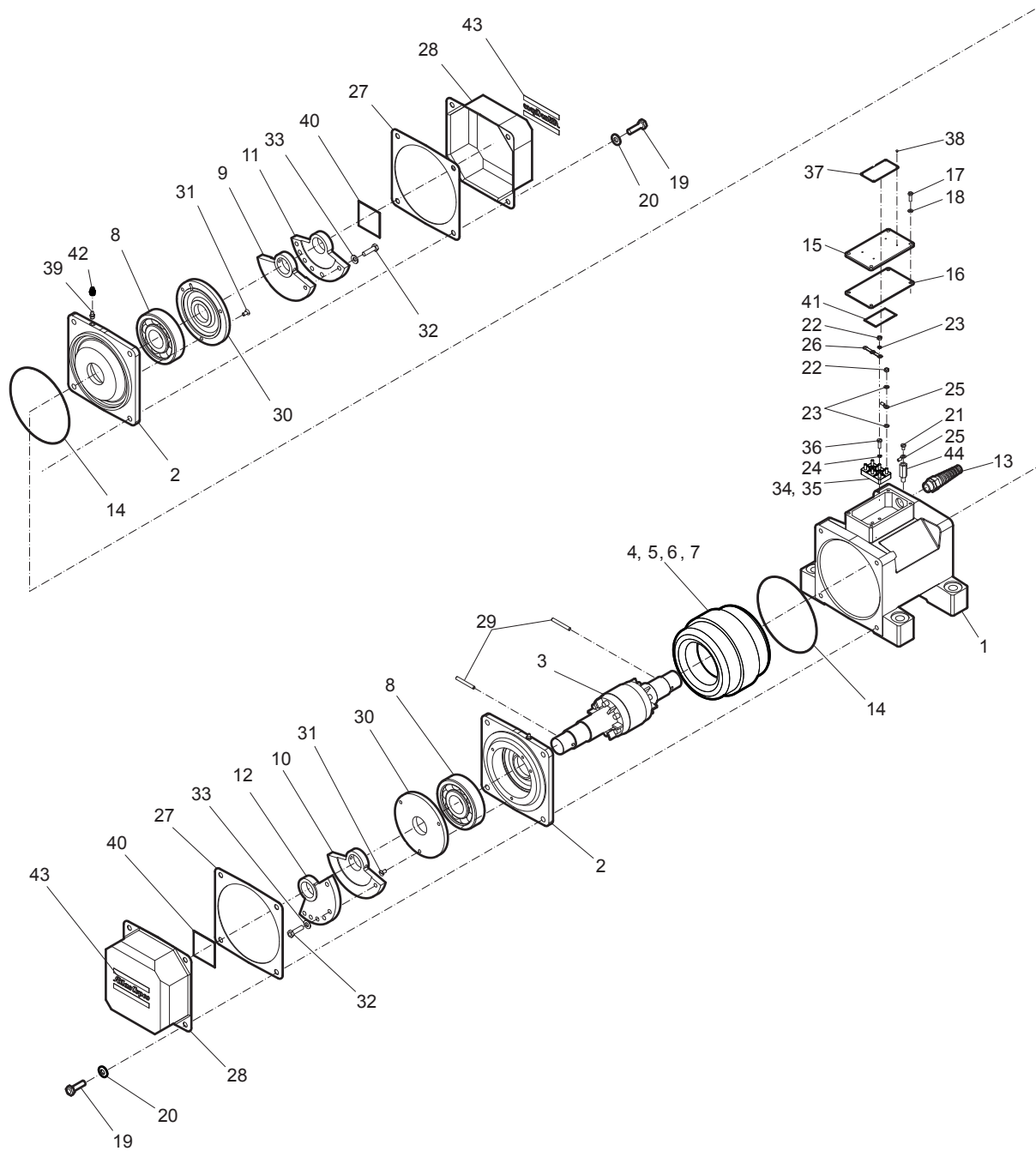

No.	Description	Remark	Quantity	Part number
1	Bolt casing		1	4700 1847 52
2	Bearing bracket		2	4700 1847 53
3	Rotor		1	4700 1848 69
4	Stator	220V/380V-3-60Hz	1	4700 1863 31
5	Stator	220V/440V-3-60Hz	1	4700 1865 21
6	Stator	230V/460V-3-60Hz	1	4700 1862 19
7	Stator	600V-3-60Hz	1	4700 1862 34
8	Bearing		2	4700 1112 38
9	Fixed eccentric		1	4700 1847 55
10	Fixed eccentric		1	4700 1848 66
11	Adjustable eccentric		1	4700 1848 65
12	Adjustable eccentric		1	4700 1847 54
13	Gland		1	4700 1848 26
14	O-ring	158.42 x 2.62 mm (Shore 70) 6.23 x 0.10 in.	2	4700 1853 08
15	Terminal box cover		1	4700 1843 83
16	Seal		1	4700 1843 84
17	Box cover screw	H M5 x 16 mm CL8.8 (DIN933)	4	-
18	Box cover washer		4	4700 1823 36
19	End cover screw	H M6 x 16 mm CL10.9 (DIN933)	8	4700 5000 30
20	End cover washer		8	4700 6150 44
21	Screw		1	4700 1859 15
22	Nut		15	4700 1836 94
23	Washer		6	4700 6150 01
24	Terminal board washer		5	4700 6060 02
25	Spade		9	4700 1800 81
26	Terminal		3	4700 1836 93
27	End cover seal		2	4700 1848 73
28	End cover		2	4700 1847 58
29	Pin	Ø6 x 50 mm (ISO8752) 0.23 x 1.96 in.	2	4700 6290 43
30	Bearing cover		2	4700 9324 07
31	Bearing cover screw	F S M6 x 16 mm CL4.8 (DIN963A)	6	4700 5350 14
32	Eccentric screw	H M8 x 30 mm CL10.9 (DIN933)	2	4700 5000 22
33	Eccentric washer	M8 (DIN6796)	2	4700 6150 43
34	Terminal board	6 poles*	1	4700 1847 89
35	Terminal board	9 poles*	1	4700 1837 15
36	Terminal board screw	C S M5 x 16 mm CL4.8 (DIN84A)	2	4700 5330 27
37	Data plate		1	-
38	Rivet		4	4710 1663 -1
39	Grease nipple		2	4700 0019 05
40	Centrifugal force label		2	4700 1853 09
41	Diagramm connection		1	4700 2971 43
42	Grease nipple cap		2	4700 4992 01
43	Label	"Atlas Copco"	2	4812 0510 65
44	Spacer		1	4700 3680 24

* depends on the type of vibrator

ER207B 200Hz

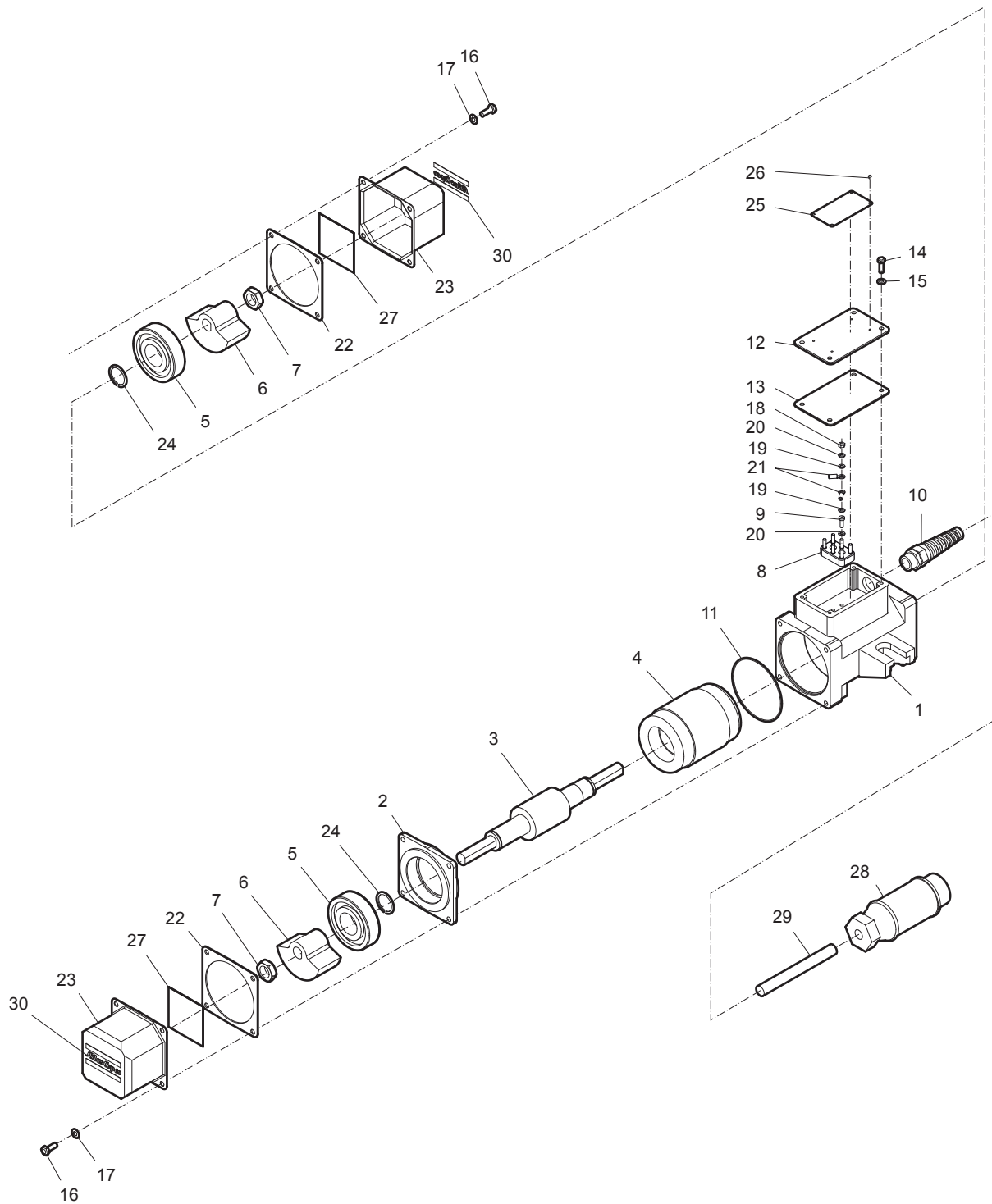

No.	Description	Remark	Quantity	Part number
1	Bracket casing		1	4700 1843 75
2	Bearing bracket		1	4700 1843 76
3	Rotor		1	4700 1847 71
4	Stator	42V-3-200Hz	1	4700 1809 17
5	Bearing		2	4700 1808 09
6	Eccentric		22	4700 1872 24
7	Nut		2	4700 1847 74
8	Terminal board	6 poles	1	4700 1036 32
9	Terminal board screw	C S M4 x 12 mm CL4.8 (DIN84A)	2	4700 5330 09
10	Gland		1	4700 1848 27
11	O-ring	82.3 x 1.78 mm (Shore 70) 3.24 x 0.07 in.	1	4700 1602 29
12	Cover		1	4700 1808 88
13	Rubber sealing		1	4700 1036 93
14	Screw	H M5 x 16 mm CL8.8 (DIN933)	4	-
15	Spring washer		4	4700 1823 36
16	Screw	H M6 x 16 mm CL10.9 (DIN933)	8	4700 5000 13
17	Washer	6.4 x 14 x 1.5 mm (DIN6796) 0.25 x 0.55 x 0.05 in.	8	4700 6150 42
18	Nut		3	4700 1838 97
19	Washer	4.3 x 8 x 0.5 mm (ISO7092) 0.16 x 0.31 x 0.01 in. Brass	6	4700 6150 05
20	Washer	4.3 x 8 x 0.5 mm (DIN6798 A) 0.16 x 0.31 x 0.01 in.	5	4700 6060 01
21	Spade		6	4700 9600 65
22	Paper seal		2	4700 1843 78
23	Cover		2	4700 1843 77
24	Retaining ring		2	4700 1500 09
25	Data plate		1	-
26	Rivet		4	4710 1663 -1
27	Label		2	4700 1849 70
28	Plug		1	4700 9450 35
29	Electric cable	L=0.6 m 1.96 ft	1	4700 9010 21
30	Lable	"Atlas Copco"	2	4812 0511 61

ER407B 200Hz

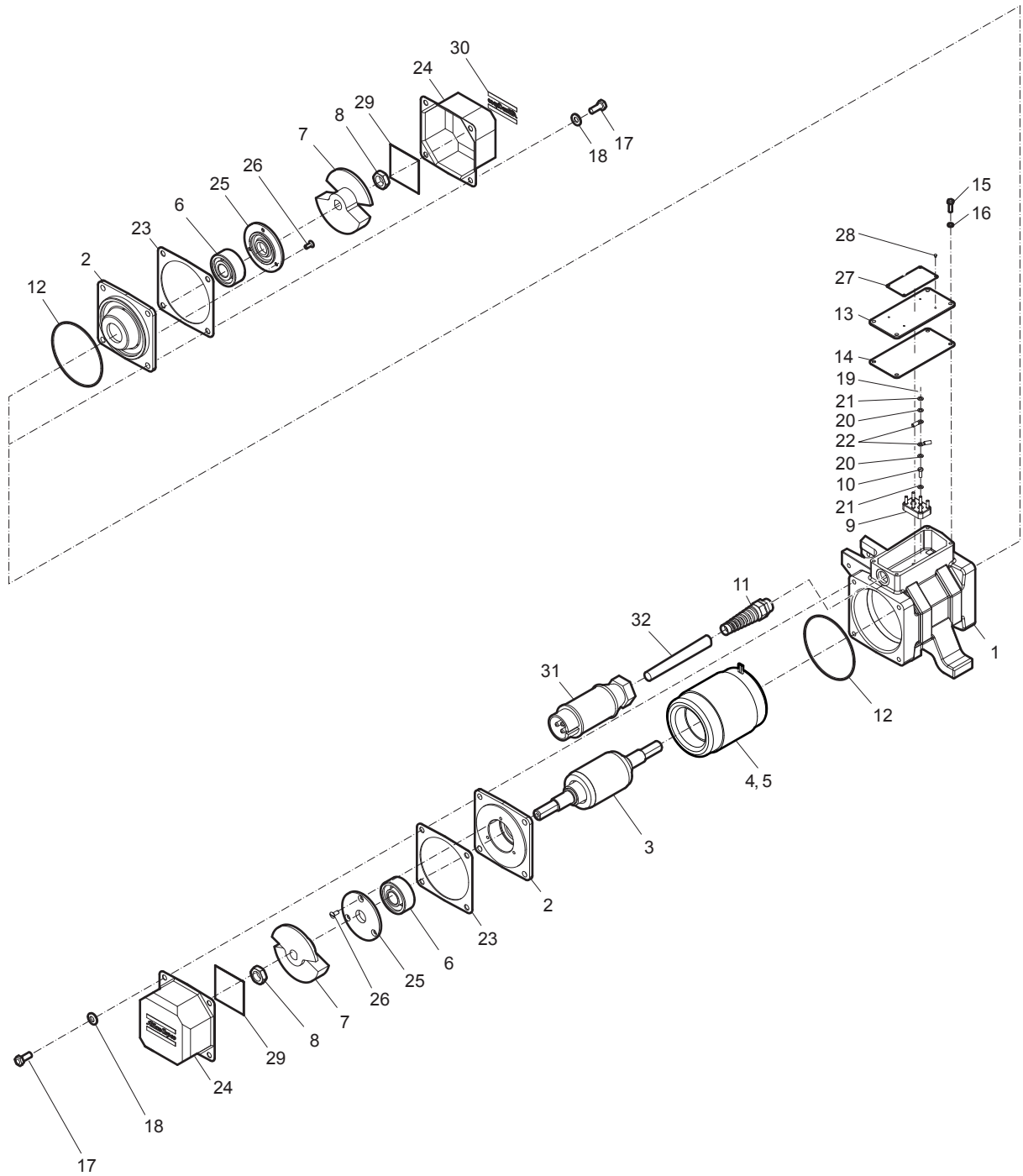

No.	Description	Remark	Quantity	Part number
1	Bracket casing		1	4700 1847 43
2	Bearing bracket		2	4700 1847 45
3	Rotor		1	4700 1848 50
4	Stator	42V-3-200Hz	1	4700 1810 32
5	Stator	250V-3-200Hz	1	4700 1860 72
6	Bearing		2	4700 1848 63
7	Eccentric		22	4700 1847 49
8	Nut		2	4700 1847 74
9	Terminal board		1	4700 1036 32
10	Terminal board screw	C S M4 x 12 mm CL4.8 (DIN84A)	2	4700 5330 09
11	Gland		1	4700 1848 27
12	O-ring	95 x 2.5 mm (Shore 70) 3.74 x 0.09 in.	2	4700 1812 64
13	Cover		1	4700 1810 38
14	Seal		1	4700 1810 37
15	Screw	H M5 x 16 mm CL8.8 (DIN933)	4	-
16	Spring washer		4	4700 1823 36
17	Screw	H M8 x 20 mm CL8.8 (DIN933)	8	-
18	Spring washer	8.4 x 18 x 2.0 mm (DIN6796) 0.33 x 0.70 x 0.07 in.	8	4700 6150 43
19	Nut		6	4700 1838 97
20	Washer	5.3 x 10 x 1.0 mm (ISO7090) 0.20 x 0.39 x 0.03 in.	9	4700 6150 05
21	Washer	4.3 x 8 x 0.5 mm (DIN6798 A) 0.16 x 0.31 x 0.01 in.	5	4700 6060 01
22	Spade		6	4700 9600 65
23	Ring		2	4700 1847 50
24	Cover		2	4700 1847 46
25	Deflector		2	4700 1847 47
26	Screw	M5 x 12 CL4.8 (DIN966A)	6	4700 1835 27
27	Data plate		1	-
28	Rivet		4	4710 1663 -1
29	Label		2	4700 1849 70
30	Label	"Atlas Copco"	2	4812 0510 93
31	Plug		1	4700 9450 35
32	Electric cable	L=0.6 m 1.96 ft	1	4700 9010 21

ER507B 200Hz

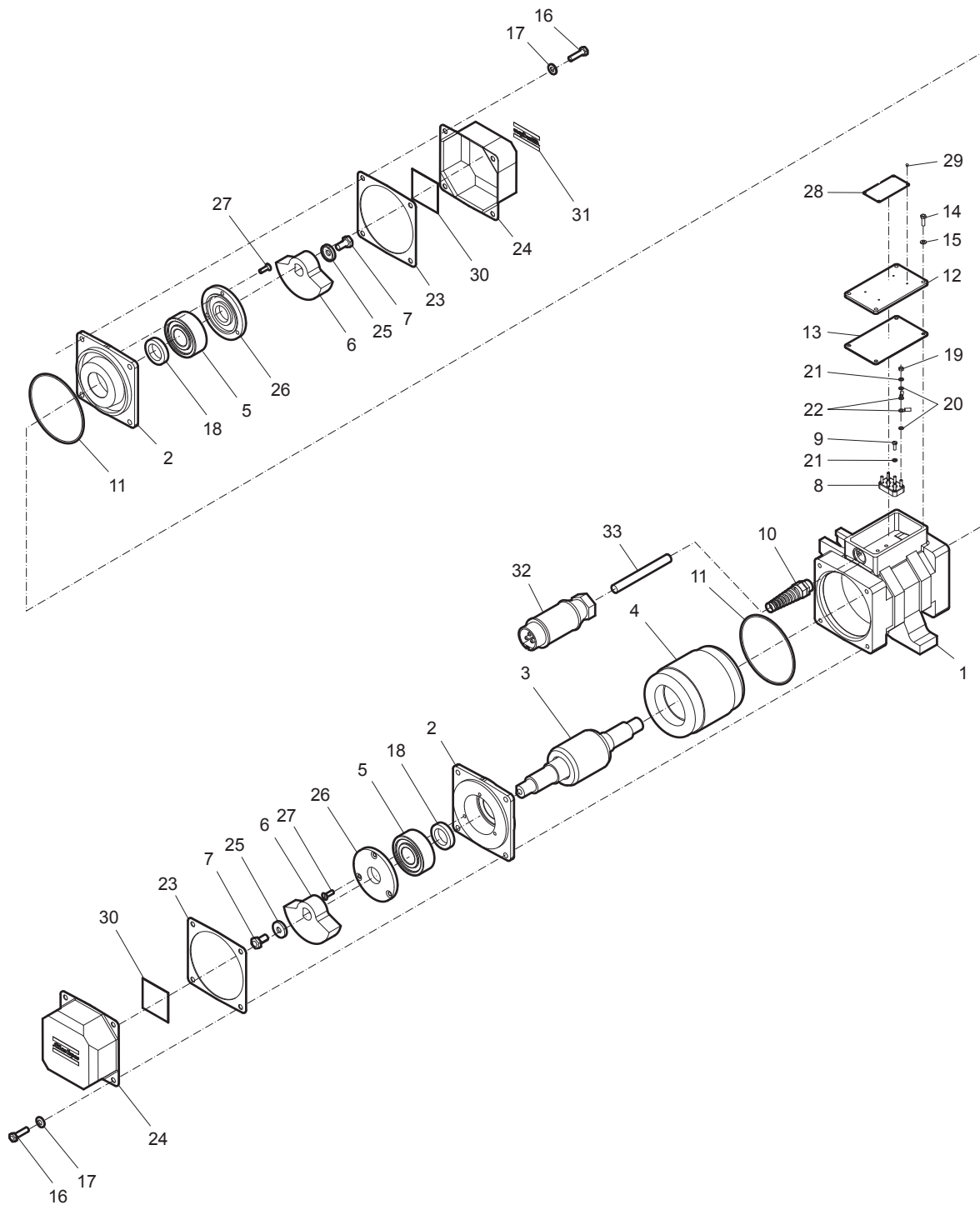

No.	Description	Remark	Quantity	Part number
1	Bracket casing		1	4700 1847 59
2	Bearing bracket		2	4700 1847 51
3	Rotor		1	4700 1847 99
4	Stator	42V-3-200Hz	1	4700 1809 09
5	Bearing		2	4700 1837 99
6	Eccentric		22	4700 1809 08
7	Screw	H M10 x 20 mm CL8.8 (DIN933)	2	-
8	Terminal board		1	4700 1847 89
9	Terminal board screw		2	4700 5330 27
10	Gland		1	4700 1848 26
11	O-ring		2	4700 1602 31
12	Cover		1	4700 1843 83
13	Rubber seal		1	4700 1843 84
14	Screw	H M5 x 16 mm CL8.8 (DIN933)	4	-
15	Spring washer		4	4700 1823 36
16	Screw	H M8 x 30 mm CL10.9 (DIN933)	8	4700 5000 22
17	Spring washer	8.4 x 18 x 2.0 mm (DIN6796) 0.33 x 0.70 x 0.07 in.	8	4700 6150 43
18	Spacer		2	4700 1848 00
19	Nut		3	4700 1836 94
20	Washer	5.3 x 10 x 1.0 mm (ISO7090) 0.20 x 0.39 x 0.03 in. Brass	6	4700 6150 01
21	Washer	5.1 x 9 x 0.5 mm (DIN6798 A) 0.20 x 0.35 x 0.01 in.	5	4700 6060 02
22	Spade		6	4700 1800 81
23	Sealing		2	4700 1843 85
24	Cover		2	4700 1843 82
25	Washer		2	4700 1847 91
26	Bearing cover		2	4700 9322 03
27	Screw	F S M6x16 mm CL4.8 (DIN963A)	6	4700 5350 14
28	Data plate		1	-
29	Rivet		4	4700 1016 63
30	Label		2	4700 1849 70
31	Label	"Atlas Copco"	2	4812 0510 65
32	Plug		1	4700 9450 35
33	Electric cable	L=0.6 m 1.96 ft	1	4700 9010 21

Any unauthorized use or copying of the contents or any part thereof is prohibited.
This applies in particular to trademarks, model denominations, part numbers, and
drawings.

© 2013 Atlas Copco Construction Tools AB | No. 9800 1200 b_b | 2013-12-11

Atlas Copco

www.atlascopco.com